



# Installation Manual

## ● Type : Enclosed Type Redundancy Module

ERDN20-05	INPUT : 1 : 4.5-6VDC	20A	OUTPUT : 20A (max)
	2 : 4.5-6 VDC	20A	
ERDN20-12	INPUT : 1 : 9-14VDC	20A	OUTPUT : 20A (max)
	2 : 9-14 VDC	20A	
ERDN20-24	INPUT : 1 : 19-29VDC	20A	OUTPUT : 20A (max)
	2 : 19-29VDC	20A	
ERDN20-48	INPUT : 1 : 36-60VDC	20A	OUTPUT : 20A (max)
	2 : 36-60VDC	20A	
ERDN40-12	INPUT : 1 : 9-14VDC	40A	OUTPUT : 40A (max)
	2 : 9-14 VDC	40A	
ERDN40-24	INPUT : 1 : 19-29VDC	40A	OUTPUT : 40A (max)
	2 : 19-29VDC	40A	
ERDN40-48	INPUT : 1 : 36-60VDC	40A	OUTPUT : 40A (max)
	2 : 36-60VDC	40A	

## ● Introduction

ERDN20/40 is an enclosed type redundancy module. Enclosed type redundancy modules possess a metal case for covering their internal PCB and will be installed inside the case of the end system. As a backup application, enclosed type redundancy modules are matched with the external voltage source to ensure that the system is stable operation.

## ● Installation

- (1) Before any installation or maintenance work, please disconnect your system from the utility or DC voltage source. Ensure that it can't be re-connected inadvertently!
- (2) Keep enough insulation distance between mounting screws and internal components of power supplies. Please refer to case drawing on specifications to receive the maximum length of mounting screw.
- (3) Mounting orientations other than standard orientation or operate under high ambient temperature may increase the internal component temperature and will require a de-rating in output current. Please refer to the specification sheets to receive the optimum mounting position and information about the de-rating curve.
- (4) Fans and ventilation holes must be kept free from any obstructions. Also a 10-15 cm clearance must be kept when the adjacent device is a heat source.
- (5) Recommended wires are shown as below.

AWG	18	16	14	12	10	8	6
Rated Current of Equipment (Amp)	7A	10A	15A	20A	30A	40A	50A
Cross-section of Lead(mm <sup>2</sup> )	0.8	1.3	2.1	3.3	5.3	8.4	13.3

Note: 1. Current each wire carries should be de-rated to 80% of the current suggested above when using 5 or more wires connected to the unit.

2. The maximum allowable wire cross-sectional area for the terminal is 6AWG/13.3 mm<sup>2</sup>

Make sure that all strands of each stranded wire enter the terminal connection and the screw terminals are securely fixed to prevent poor contact.

- (6) For other information about the products, please refer to [www.meanwell.com](http://www.meanwell.com) for details.

## ● Typical Application Notes

### (1) 1+1 Redundancy:

Using 1 more PSU as the redundant unit

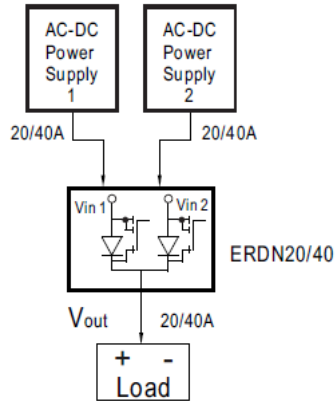

### (2) 1+N Redundancy:

Using more PSUs as the redundant units to increase the reliability

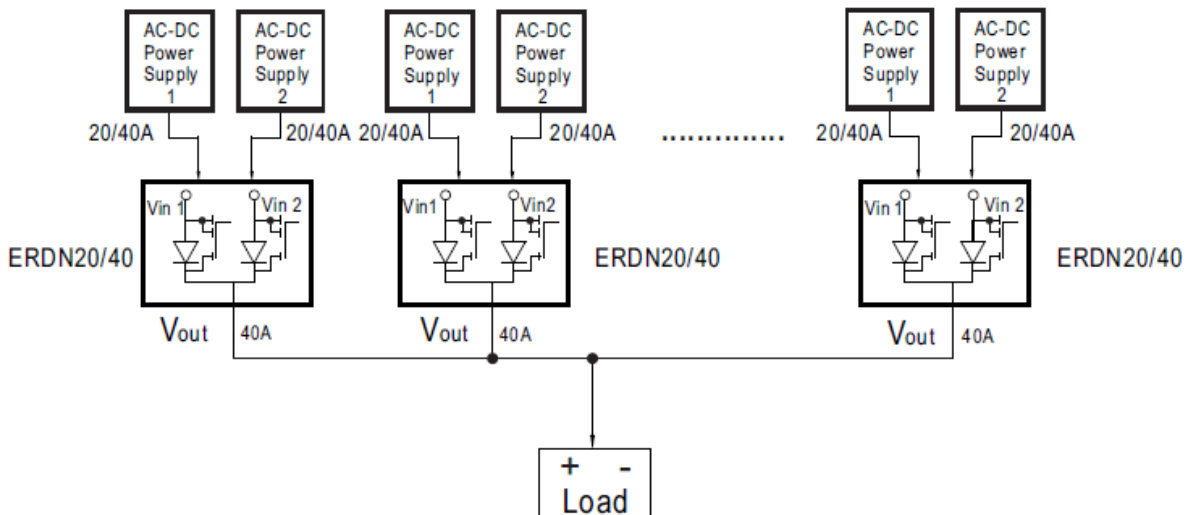

### (3) Single Use:

Connecting only one PSU to one ERDN20/40 to reduce the stress of the MOSFET and hence increase the reliability

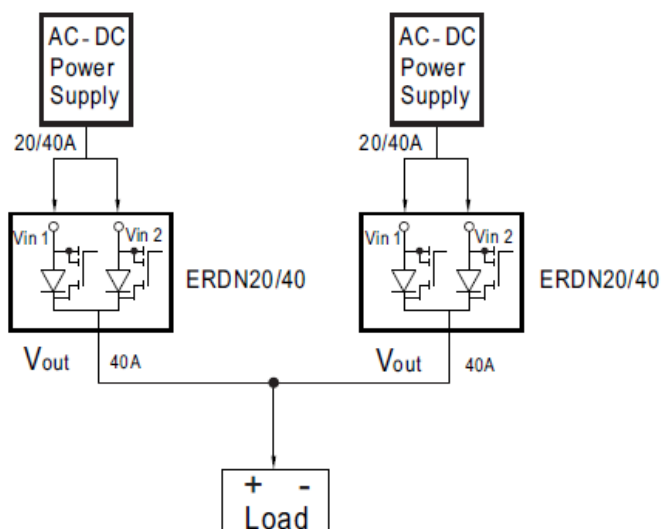



# Installation Manual

## ● **Warning / Caution !!**

- ( 1 ) Risk of electrical shock and energy hazard. All failure should be examined by a qualified technician. Please do not remove the case of the power supply by yourself!
- ( 2 ) Please do not install power supplies in places with high moisture or near the water.
- ( 3 ) Please do not install power supplies in places with high ambient temperature or near fire source. The maximum ambient temperature please refer to their specifications.
- ( 4 ) Output current and output wattage must not exceed the rated values on specifications.
- ( 5 ) The ground(FG) must be connected to earth ground.
- ( 6 ) All MW's PSUs are designed in accordance with EMC regulations and the related test reports are available by request. Since they are belong to component power supplies and will be installed inside system enclosure, when they are integrated into a system, the EMC characteristics of the end system must be re-verified again.

### **Manufacturer :**

MEAN WELL ENTERPRISES Co., LTD.  
No.28, Wuquan 3rd Rd., Wugu Dist.,  
New Taipei City 24891, Taiwan  
Tel: +886-2-2299-6100  
Web: [www.meanwell.com](http://www.meanwell.com)

### **Branch Office :**

#### ***China***

MEAN WELL (GUANGZHOU)  
ENTERPRISES Co., LTD.  
2F, A Building, Yuean Industry Park,  
Huangcun, Dongpu Yown, Tianhe  
District, Gungzhou, China  
Post Code:510660  
Tel: +86-20-2887-1200  
Web: [www.meanwell.com.cn](http://www.meanwell.com.cn)

#### ***China***

MEAN WELL (GUANGZHOU)  
ENTERPRISES Co., LTD.  
No.11, Jingu South Road, Huadong  
Town, Huadu Distric, Guangzhou,  
Gungzhou, China  
Tel: +86-20-3773-7100  
Web: [www.meanwell.com.cn](http://www.meanwell.com.cn)

#### ***China***

SUZHOU MEAN WELL  
TECHNOLOGY Co., LTD.  
No.77, Jian-Ming Rd. Dong-Qiao,  
Pan-Yang Ind. Park, Huang-Dai  
Town, Xiang-Cheng District,  
Suzhou, Jiang-Su, China  
Post Code:215152  
Tel: +86-512-6508-8600  
Web: [www.meanwell.cc](http://www.meanwell.cc)

#### ***U.S.A.***

MEAN WELL USA, INC.  
44030 Fremont Blvd., Fremont,  
CA 94538, U.S.A.  
Tel: +1-510-683-8886  
Web: [www.meanwellusa.com](http://www.meanwellusa.com)

#### ***Europe***

MEAN WELL EUROPE B.V.  
Langs de Werf 8, 1185XT Amstelveen, The  
Netherlands  
Tel: +31-20-758-6000  
Web: [www.meanwell.eu](http://www.meanwell.eu)