

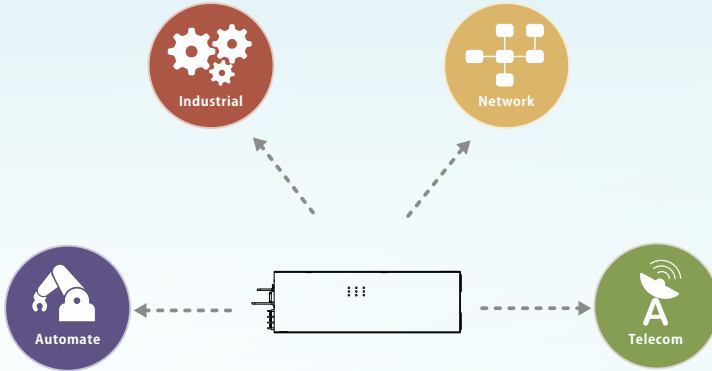

NSP-2400 Series Installation manual



2400W AC/DC High Reliable Industrial Enclosed Type Power Supply

- Output voltage 0~120% and output current 0~100% programmable
- Built-in constant current limiting circuit

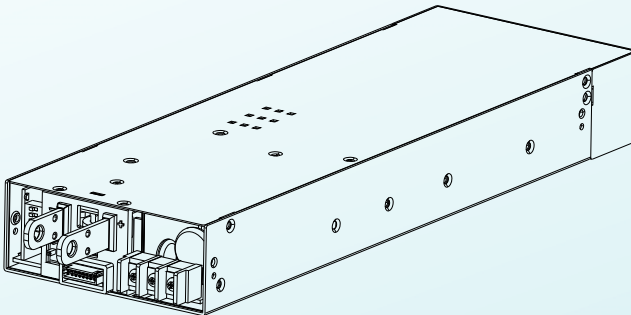

The NSP-2400 series is a 2400W AC/DC power supply with PFC function, designed for high reliability and suitable for multiple industries. Key features include: compact size (325.8*107*41mm) for better space utilization in system installations, ultra-wide input range of 85~305Vac for global compatibility, up to 93% efficiency, programmable output voltage (0~120%) and current (0~100%), constant current design with 200% peak power capability, parallel output capacity up to 9600W, built-in CANBus communication interface, wide operating temperature range from -40 to +85°C (+60°C at full load), compliance with OVCIII, built-in Remote Control /Remote Sense/DC OK signal/auxiliary power, internal PCB coating, complete protections, certifications for multiple safety standards including 62368-1, 60601-1, 61558-1, 60335-1, 62477-1, and 61010-1, as well as 2 X MOPP compliance and extremely low leakage current (<500µA). It is suitable for BF-rated medical equipment and comes with a 5-years warranty, making it a highly cost-effective solution for industrial power supply needs.

Contents

1.Safety Guidelines	1
2.Introduction	2
2.1 Model Encoding	2
2.2 Features	3
2.3 Specification	4
2.4 Derating curve	6
2.5 Static Characteristics	7
2.6 Mechanical specification	8
3.Installation & Wiring	10
3.1 Precautions	10
3.2 Installation Procedures	10
3.3 Cable Size Selection	11
4.User Interface	12
4.1 Panel Description	12
4.2 LED Indicator	13
4.3 Pin Assignment (CN1)	14
4.4 Pin Assignment (CN2)	15
4.5 Communication Address / ID Assignment	16
5.Explanation of Operation	17
5.1 Peak Power	17
5.2 Inrush Current Limiting	19
5.3 Power Factor Correction	19
5.4 DIP Switch Function	19
Overview	
5.5 Overload Protection (OLP)	20
Type Selection	
5.6 Output Voltage Adjustment	21
5.6.1 SVR	21
5.6.2 PV	21
5.6.3 Communication	22

5.7 Output Current Adjustment	22
5.7.1 P.C	22
5.7.2 Communication	23
5.8 Parallel Function	24
5.8.1 Termination Resistor	24
Setting	
5.8.2 Parallel Operation	25
Instructions	
5.9 Remote Control	26
5.10 Voltage Drop Compensation	26
(Remote Sense/Local Sense)	
5.11 Output Voltage Signal(DC-OK)	27
5.12 Auxiliary Output	27
5.13 Fan Speed Control	28
5.14 Factory Resetting	28
6.Communication Protocol	29
6.1 CAN bus Protocol	29
6.1.1 Message ID definition	30
6.1.2 CAN bus Command list	31
6.1.3 Communication Examples	39
6.2 Modbus Communication	42
Interface	
6.2.1 Communication Timing	42
6.2.2 Modbus Frame	42
Encapsulation	
6.2.3 Additional Address	43
Definition	
6.2.4 Function Code	43
Description	
6.2.5 Data Field and	43
Command Lists	
6.2.6 Communication	54
Examples	

Contents

6.3 Value range and tolerance	58
7.Protections and Trouble	61
Shooting	
7.1 Protections	61
7.1.1 Over Load Protection	61
7.1.2 Over Voltage Protection	61
7.1.3 Over Temperature	61
Protection	
7.1.4 Fan Fail Protection	61
7.1.5 Short Circuit Protection	61
7.1.6 AC Input Under-	62
Voltage Protection	
7.1.7 Under Temperature	62
Protection	
7.2 Trouble Shooting	63
8.Warranty	65
9.Environmental Declaration	66
Information	

1.Safety Guidelines

- Risk of electrical shock and energy hazard. All failures must be examined by a qualified technician. Do not remove the power supply case by yourself.
- Do not install the power supply in locations with high moisture, high ambient temperature or direct sunlight.
- AC input range: 85-305Vac, 47-63 Hz. Do not connect to AC power outside this range.
- Fans and ventilation holes must be kept free from obstructions. Maintain at least 15 cm clearance from adjacent heat source.
- Do not stack any object on the unit.
- The safety protection level of this power supply is Class I. The unit's frame ground (⏚) must be properly connected to PE (Protective Earth).

2.Introduction

2.1 Model Encoding

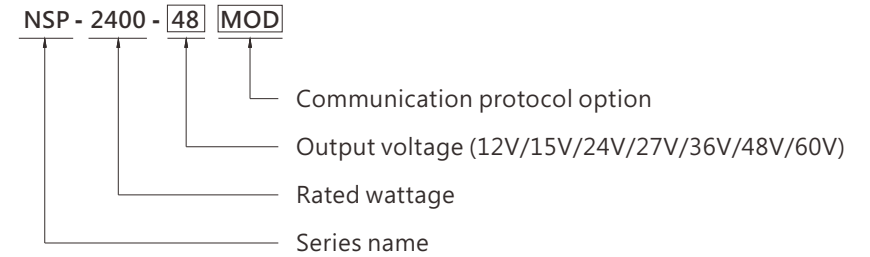

Type	Communication Protocol	Note
Blank	CANBus protocol	In Stock
MOD	MODBus protocol	By request

2.2 Features

- 85~305Vac input with PFC(277Vac available)
- Global certificates in multi-fields (ITE 62368-1, Medical 60601-1, Household 60335-1,Industrial 61558-1/2-16/61010-1/-2-201, Energy converter 62477-1), SEMI F47 at 200Vac
- 200% peak power capability
- High efficiency up to 93%
- Output voltage 0~120% and output current 0~100% programmable
- Current sharing up to 9600W(3+1) for parallel use
- Built in ORing MOS By request, Order NO. : NSP-2400-xxOR/MODOR
- CAN bus(Built in) or MODBus protocol (By request)
- -40~85°C wide range operation temperature(> +60°C derating)
- Extremely low leakage current <500uA, 2 x MOPP, suitable for BF medical applications
- Built-in constant current limiting circuit
- Protections: Short circuit / Overload / Over voltage / Over temperature
- Built-in remote ON/OFF control/Remote Sense/ DC OK signal
- Auxiliary 5Vdc and 12Vdc
- Over voltage category III (OVC III)
- Operating altitude up to 5000 meters
- Built-in intelligent fan speed control, low noise <46dB
- Conformal coating
- 5 years warranty

2.3 Specification

SPECIFICATION		NSP-2400-12	NSP-2400-15	NSP-2400-24	NSP-2400-27	NSP-2400-36	NSP-2400-48	NSP-2400-60
		□ =Blank (standard model in stock), MOD (By request model)						
OUTPUT								
DC VOLTAGE		12V	15V	24V	27V	36V	48V	60V
CURRENT		183.3A	146.7A	100A	88.8A	66.6A	50A	40A
CURRENT RANGE		0 ~ 183.3A	0 ~ 146.7A	0 ~ 100A	0 ~ 88.8A	0 ~ 66.6A	0 ~ 50A	0 ~ 40A
RATED POWER		2200W	2200W	2400W	2397W	2397W	2400W	2400W
PEAK	CURRENT	366.6A	293.3A	200A	177.6A	133A	100A	80A
	POWER	4400W	4400W	4800W	4795W	4795W	4800W	4800W
RIPPLE & NOISE (max.)	Note.3	300mVp-p	300mVp-p	300mVp-p	300mVp-p	350mVp-p	450mVp-p	600mVp-p
VOLTAGE ADJ. RANGE		10.8 ~ 14.4V	13.5 ~ 19V	21.6 ~ 28.8V	24.3 ~ 32.4V	32.4 ~ 43.2V	43.2 ~ 55V	54 ~ 72V
VOLTAGE TOLERANCE	Note.4	±1.0%						
LINE REGULATION	Note.4	±0.5%						
LOAD REGULATION		±0.5%						
SETUP, RISE TIME	Note.5	1800ms, 60ms/115Vac; 1800ms, 60ms/230Vac; 1800ms, 60ms/277Vac at full load						
HOLD UP TIME (Typ.)		12ms @ 70% load, 8ms @full load						
INPUT								
VOLTAGE RANGE	Note.6	85 ~ 305Vac	250 ~ 431Vdc					
FREQUENCY RANGE		47 ~ 63Hz						
POWER FACTOR (Typ.)		0.98/115Vac	0.95/230Vac	0.93/277Vac at full load				
EFFICIENCY (Typ.)		89%	90%	91%	91%	91.5%	92%	93%
AC CURRENT (Typ.)		17A/115Vac	13A/230Vac	11A/277Vac				
INRUSH CURRENT (Typ.)		COLD START 30A/115Vac	60A/230Vac	75A/277Vac				
LEAKAGE CURRENT		Earth leakage current <500uA(rms)@277Vac; Touch current<100uA(rms) @ 277Vac						
PROTECTION								
SHORT CIRCUIT	PEAK POWER MODE	Constant current limiting, unit will shut down after 5 Sec, AC repower on to recover. (2 Sec for 12V/15V models)						
	CURRENT LIMITING MODE	Constant current limiting, recovers automatically after abnormal condition is removed						
OVERLOAD	PEAK POWER MODE	From 105% to 200% of rated output power, unit will shut down after 5 seconds of continuous operation. AC repower on to recover. (2 Sec for 12V/15V models)						
	CURRENT LIMITING MODE	At >200% of rated output power, constant current limiting is activated. Unit will shut down after 5 seconds of continuous operation. AC repower on to recover. (2 Sec for 12V/15V models)						
OVER VOLTAGE		15 ~ 19V	20 ~ 25V	29 ~ 37V	33 ~ 42V	44 ~ 54V	56 ~ 60V	73 ~ 86V
OVER TEMPERATURE		Protection type : Shut down and latch off output voltage, re-power on to recover						
FUNCTION								
OUTPUT CURRENT PROGRAMMABLE(PC)		Adjustment of constant current level is allowable between 0 ~ 100% of rated current. Please refer to the Function Manual.						
OUTPUT VOLTAGE PROGRAMMABLE(PV)	Note.9	Adjustment of output voltage is allowable to 0 ~ 120% of nominal output voltage. Please refer to the Function Manual.						
PARALLEL		Up to 9600W or (3+1) units. Please refer to the Function Manual.						
AUXILIARY POWER		5Vaux @ 0.2A Tolerance ±15%, ripple 150mVp-p 12Vaux @ 0.8A Tolerance ±15%, ripple 450mVp-p						
REMOTE CONTROL		By electrical signal or dry contact Power ON: RC short Power OFF: RC open						
REMOTE SENSE		Compensate voltage drop on the load wiring up to 0.5Vdc						
DC OK SIGNAL		Contact rating(max.):5Vdc/10mA resistive load						
CANBus(BUILT-IN) or MODBus(By Request) INTERFACE		Communication provides functions such as control, setting and monitoring						
FAN NOISE (Typ.)	Note.10	Built-in intelligent fan speed control detect by PSU'S internal temperature						
		10% load with Ta=25°C	38dB					
		70% load with Ta=25°C	46dB	44dB	44dB	42dB	38dB	40dB
								41dB
ENVIRONMENT								
WORKING TEMP.		-40 ~ +85°C (Refer to "Derating Curve")						
WORKING HUMIDITY		20 ~ 90% RH non-condensing						
STORAGE TEMP., HUMIDITY		-40 ~ +85°C, 10 ~ 95% RH non-condensing						
TEMP. COEFFICIENT		±0.03%/°C (0 ~ 60°C)						
VIBRATION		10 ~ 500Hz, 2G 10min./1cycle, 60min. each along X, Y, Z axes						

SAFETY & EMC(Note 11-13)				
SAFETY STANDARDS	CB DEKRA	IEC62368-1, IEC60335-1, IEC61558-1/2-16, IEC61010-1/2-201, IEC60601-1, IEC62477-1 BS EN/EN62368-1, BS EN/EN60335-1, BS EN/EN61558-1/2-16, BS EN/EN61010-1/2-201, BS EN/EN60601-1(3.2 Version), BS EN/EN62477-1		
	UL	UL62368-1, ANSI/AAMI ES60601-1(3.2 Version), UL61010-1/2-201		
ISOLATION LEVEL	QCQC	GB4943.1		
	BSMI	CNS15598-1		
	EAC	TP TC 004		
	SEMI F47	approved		
	KC/BIS	KC 62368-1 and BIS IS 13252(Part 1) certified, No stock, contact sales by request		
ISOLATION LEVEL	Note.14	Primary-Secondary: 2xMOPP, Primary-Earth: 1xMOPP, Secondary-Earth: 1xMOPP		
OVER VOLTAGE CATEGORY	Note.15	IEC/EN 61558-1/2-16	(OVC III, altitude up to 2000M)	
		IEC/EN/UL 62368-1	(OVC II, altitude up to 3000M)	
		IEC/EN 60335-1	(OVC II, altitude up to 5000M)	
		IEC/EN/ANSI/AAMI ES60601-1	(OVC II, altitude up to 4000M)	
		IEC/EN/UL 61010-1/2-201	(OVC II, altitude up to 5000M)	
SAFETY EXTRA-LOW VOLTAGE(SELV)	IEC/EN 61558-2-16 (SELV, 12 ~ 60V) IEC/EN 60335-1 (SELV, 12 ~ 36V) IEC/EN/UL 62368-1 (SELV/ES1, 12 ~ 48V)			
WITHSTAND VOLTAGE	IIP-O/P:4KVac IIP-FG:2KVac OIP-FG:1.5KVac			
ISOLATION RESISTANCE	IIP-O/P, IIP-FG, OIP-FG:100M Ohms / 500VDC / 25°C / 70% RH			
EMC EMISSION	Conducted	Parameter	Standard	Test Level / Note
			BS EN/EN55032(CISPR32), CNS 15936, GB/T 9254.1, KS C 9832	Class B
	Radiated		BS EN/EN55014-1(CISPR14-1)	
			BS EN/EN55011(CISPR11)	Class B
			BS EN/EN55032(CISPR32), CNS 15936, GB/T 9254.1, KS C 9832	Class B
			BS EN/EN55014-1(CISPR14-1)	
	Harmonic Current		BS EN/EN61000-3-2(IEC61000-3-2), GB 17625.1	Class A
	Voltage Flicker		BS EN/EN61000-3-3(IEC61000-3-3)	-----
	EMC IMMUNITY	BS EN/EN55035(CISPR35), BS EN/EN61000-6-2(IEC61000-6-2), BS EN/EN60601-1-2(IEC60601-1-2), BS EN/EN55014-2(CISPR14-2), KS C 9835, SEMI F47 tested at 200Vac		
		Parameter	Standard	Test Level / Note
ESD		BS EN/EN61000-4-2	Level 4, 15KV air ; Level 4, 8KV contact	
Radiated		BS EN/EN61000-4-3	Level 3, 10V/m(80MHz-2.7GHz) Table 9, 9-28V/m(385MHz-5.78GHz)	
EFT / Burst		BS EN/EN61000-4-4	Level 3, 2KV	
Surge		BS EN/EN61000-4-5	Level 4, 2KV/Line-Line 4KV/Line-Earth	
Conducted		BS EN/EN61000-4-6	Level 3, 10V	
Magnetic Field		BS EN/EN61000-4-8	Level 4, 30A/m	
Voltage Dips and Interruptions		BS EN/EN61000-4-11	>95% dip 0.5 periods, 30% dip 25 periods, >95% interruptions 250 periods	
OTHERS				
MTBF	566.1K hrs min. Telcordia SR-332 (Bellcore) ; 47.3K hrs min. MIL-HDBK-217F (25°C)			
DIMENSION (L*W*H)	325.8*107*41mm			
PACKING	2.32Kg/4pcs/10.3Kg/1.09CUFT			
NOTE	<ol style="list-style-type: none"> All parameters NOT specially mentioned are measured at 230Vac input, rated load and 25°C of ambient temperature. The peak power duration is 2 seconds for 12V/15V models and 5 seconds for all other models. Ripple & noise are measured at 20MHz of bandwidth by using a 12" twisted pair-wire terminated with a 0.1uF & 47uF parallel capacitor. Tolerance: includes set up tolerance, line regulation and load regulation. Setup time is measured at the first cold start. Derating may be required at low input voltages; refer to the "Static Characteristics" section for details. Operation under stabilized output voltage may trigger protective shutdown. For details on the overload protection mode, refer to the "Overload Protection Mode" section in the User Manual. When the output voltage is adjusted via the PV function, the output ripple and noise may exceed the specified limits under certain operating conditions. Fan noise measurement is performed in accordance with ISO 7779. The Regulatory Compliance Mark (RCM) is applied on a voluntary basis. The equipment meets the relevant IEC or AS/NZS standards, or AS/NZS 3820 where applicable. The use of the RCM mark complies with AS/NZS 4417.1. The power supply is considered a component which will be installed into a final equipment. All the EMC tests are been executed by mounting the unit on a 380mm*360mm metal plate with 1mm of thickness. The final equipment must be re-confirmed that it still meets EMC directives. For guidance on how to perform these EMC tests, please refer to "EMI testing of component power supplies." (as available on https://www.meanwell.com/Upload/PDF/EMI_statement_en.pdf) The BIS marking may not be available for certain manufacturing sites or models. Please contact your MEAN WELL sales rep for further information. MOPP is suitable for 100-240Vac input only. The ambient temperature derating of 3.5°C/1000m with fanless models and 5°C/1000m with fan models for operating altitude higher than 2000m(6500ft). 			
※ Product Liability Disclaimer : For detailed information, please refer to https://www.meanwell.com/serviceDisclaimer.aspx				

2.4 Derating Curve

◎ 12V/15V

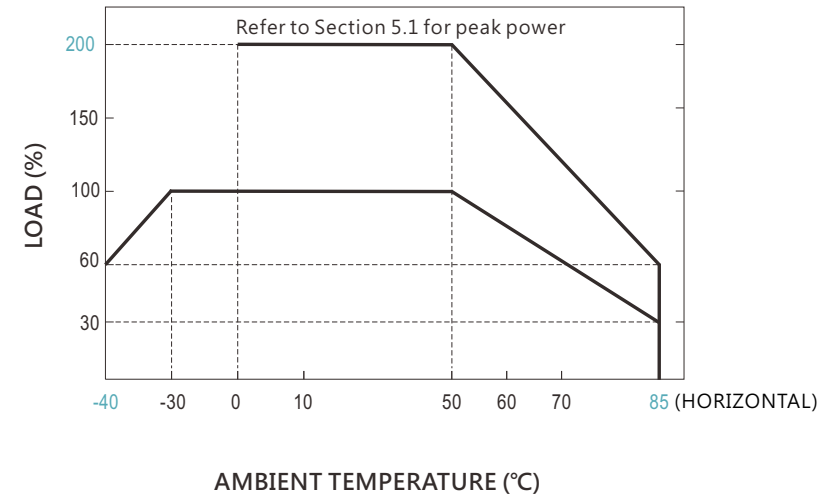

◎ Others

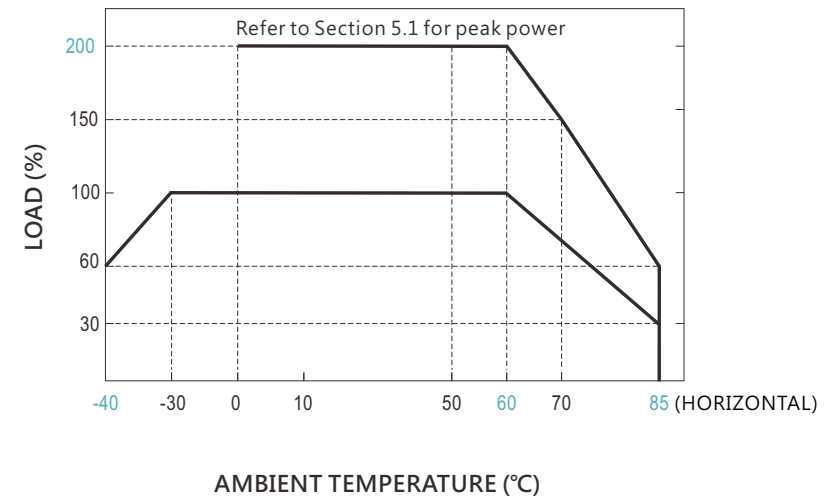

2.5 Static Characteristics

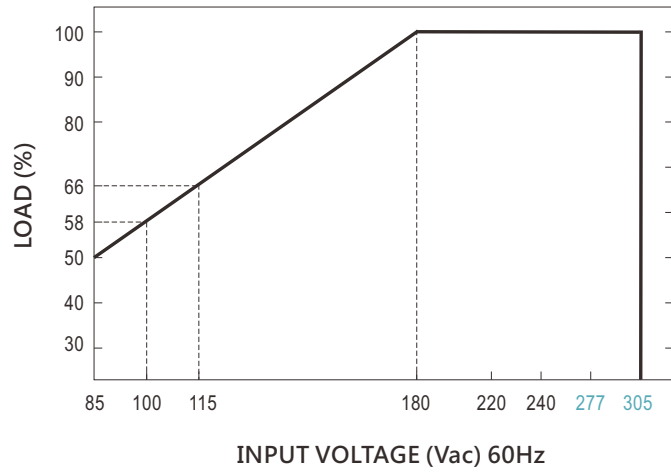

2.6 Mechanical specification

(Unit: mm, tolerance ± 0.5 mm)

Case No.294A

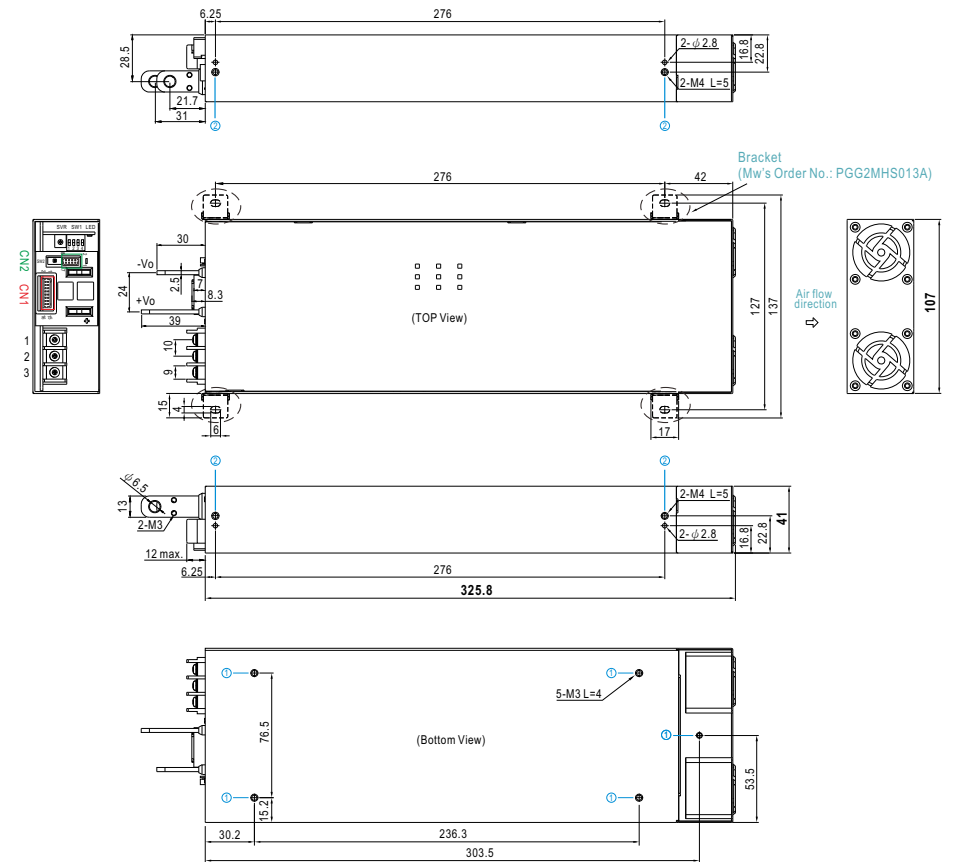

※ Mounting Instruction

Hole No.	Recommended Screw Size	MAX. Penetration Depth L	Recommended mounting torque
①	M3	4mm	6~8Kgf-cm
②	M4	5mm	7~10Kgf-cm

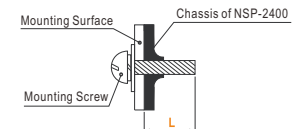

※ Terminal Pin No.

Pin No.	Assignment	Terminal	Screw Thread	Max. mounting torque
1	FG ↓		M3.5	8Kgf-cm
2	AC/N			
3	AC/L			

※ Accessory List :

No.	Item	Quantity
1	Remote Sense(CN1) mating wire along with NSP-2400 (standard accessory)	1pcs/per model
2	Remote Control(CN2) mating wire along with NSP-2400 (standard accessory)	1pcs/per model
3	Bracket Mw's Order No.: PGG2MHS013A (Optional accessories can be purchased separately)	4pcs/per model (Please refer to Installation Diagram)
4	Terminal cover Mw'S Order NO. :PEE4TBC-03-DG (Optional accessories can be purchased separately)	1pcs/per model

※ Installation Diagram

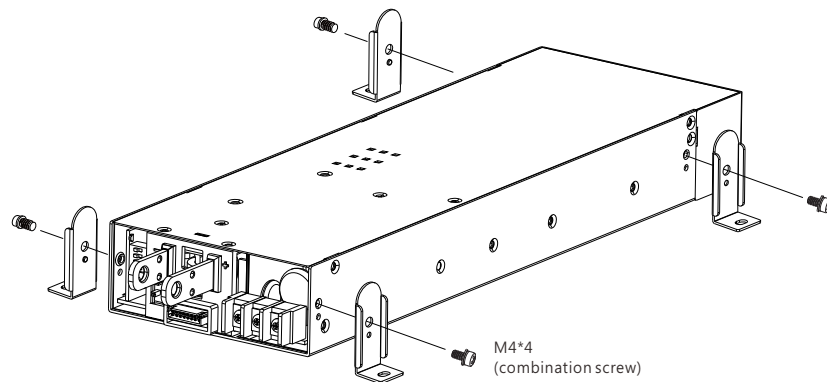

3.Installation & Wiring

3.1 Precautions

- Ensure the system chassis has sufficient strength to support the unit.
- To ensure the lifespan of the unit, do not operate the unit in high-dust or high-moisture environments.
- The NSP-2400 series is designed with built-in DC fans. Ensure the ventilation is not blocked and maintain at least 15 cm clearance around the ventilation openings.

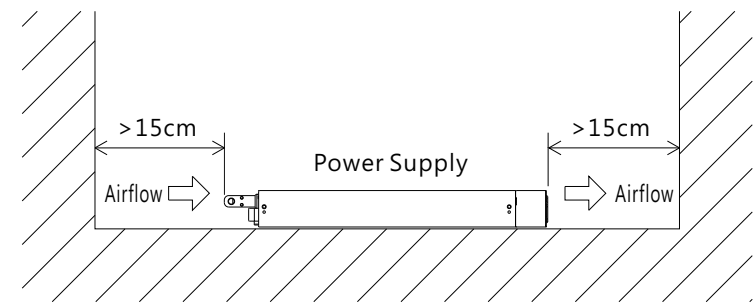

Figure 3-1 Mounting Diagram

3.2 Installation Procedures

- ① Select cables with appropriate wire gauge for the input and output connections of NSP-2400 series. Refer to 3.3 for cable size selection.
- ② Ensure the AC input and DC output terminals of the NSP-2400 series are correctly connected. Do not reverse the DC output polarity or cause a short circuit.

3.3 Cable Size Selection

Wire connection should be as short as possible, preferably less than 1 meter. Ensure wires are selected according to applicable safety requirements and current rating. A smaller cross-section will reduce efficiency, limit the output power, and may cause the wires to overheat, creating a potential safety hazard.

- ① AC input side: It is recommended to use 12 AWG wires.
- ② DC output side: Refer to Table 3-1 for wire recommendations.

AWG	Cross-section on Area (mm ²)	Maximum DC current(A)
8	6	40A
6	10	60A
4	16	80A
2	25	100A
1	35	125A
0	50	160A
000	75	190A
0000	95	230A

4.User Interface





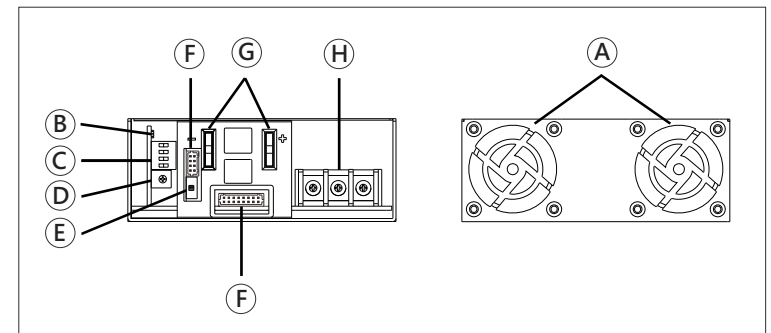

4.1 Panel Description

- (A) Ventilation holes for fans:**
The power supply requires adequate ventilation to operate properly. Ensure sufficient airflow to maintain the optimal performance and extend service life.
- (B) LED indicator:**
The LED Indicator shows the operating status. Refer to Section 4.2 for details.
- (C) DIP switch:**
Set the power supply to a specific operating mode. Refer to Section 5.4 for details.
- (D) SVR:**
This is used to adjust the DC output voltage.
- (E) SW2 switch:**
Termination resistor (120Ω) for CAN Bus/Modbus communication. This is used to stabilize the communication signal.
- (F) Connection ports (CN1 and CN2):**
The connection ports are used to switch operating modes and monitor the power supply status. Refer to Section 4.3 and Section 4.4 for pin assignment.
- (G) DC output terminals:**
Refer to Section 3.3 for wiring instructions. Use M6 screws for connection with a recommended torque of 33.1 kgf-cm. Screws and other accessories are included in the accessory bag.
- (H) AC input terminals:**
It is recommended to use 12 AWG wires. Use M3.5 screws for connection with a recommended torque of 8 kgf-cm.



4.2 LED Indicator

The power supply monitors its operating status and displays the corresponding status through different LED colors and blink patterns, as shown in the table below. Refer to Chapter 7 for explanations of the fault causes and troubleshooting methods.

LED Status	Description
● Green	Normal operation
● Red	Remote OFF
☀ Orange: 1 Blink/Pause 	High ambient temperature alarm (Note 1)
☀ Red: 1 Blink/Pause 	Overload Protection (OLP)/ Short Circuit Protection (SCP)(Note 2)
☀ Red: 2 Blink/Pause 	Over Voltage Protection (OVP)
☀ Red: 3 Blink/Pause 	Over Temperature Protection (OTP)
☀ Red: 4 Blink/Pause 	Fan Fail
☀ Red: 5 Blink/Pause 	AC Input Under Voltage Protection (AC_UVP)
☀ Red: 6 Blink/Pause 	Others(Note 3)

Note 1.The high ambient temperature alarm is for notification purposes only and will not shut down the output.

Note 2: When the OLP mode is set to constant current limiting (refer to Section 5.5), the PSU can operate continuously in constant current mode. In this state, OLP is disabled, and the corresponding LED alarms will not displayed.

Note 3.Under-temperature protection and EEPROM access error...etc. are included in this error code.

4.3 Pin Assignment (CN1)

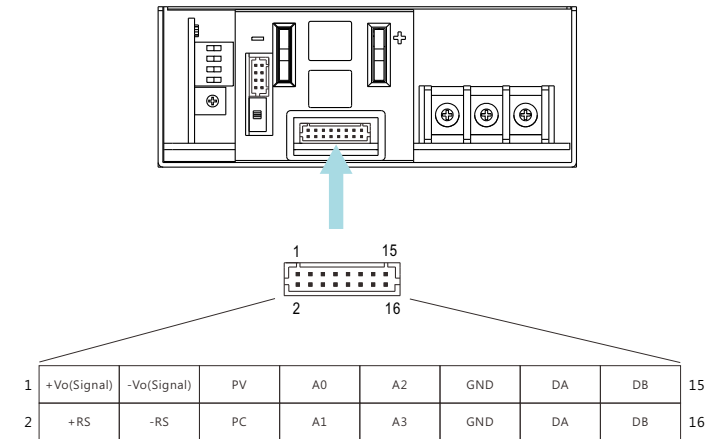

Connect Pin No. Assignment: HRS DF11-16DP-2DS or equivalent

Pin No.	Function	Description
1	+Vo(Signal)	Positive output voltage signal. It is for local sense and cannot be connected directly to the load.
2	+RS	Positive sensing for remote sense.
3	-Vo(Signal)	Negative output voltage signal. It is for local sense, certain function reference, and cannot be connected directly to the load.
4	-RS	Negative sensing for remote sense.
5	PV	Connection for output voltage programming. (Note.)
6	PC	Connection for output current programming. (Note.)
7,8,9,10	A0,A1,A2,A3	Interface addresses lines. Refer to Section 4.5 for details.
11,12	GND	These pins connect to the negative terminal (-Vo).
13,14	DA	Differential digital signal for parallel control.
15,16	DB	Differential digital signal for parallel control.

Note. Non-isolated signal, referenced to (GND).

4.4 Pin Assignment (CN2)

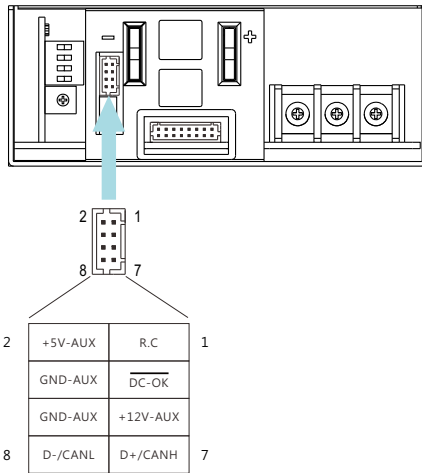

Connect Pin No. Assignment: HRS DF11-8DP-2DS or equivalent

Pin No.	Function	Description
1	R.C	The unit can turn the output ON/OFF by electrical signal or dry contact between R.C and +5V-aux. (Note) Short (4.5 ~ 5.5Vdc) : Power ON ; Open (-0.5 ~ 0.5Vdc) : Power OFF ; The maximum input voltage is 5.5Vdc.
2	+5V-AUX	Auxiliary voltage output, 4.25~5.75Vdc, referenced to GND-aux. The maximum load current is 0.2A. This output has the built-in "Oring diodes" and is not controlled by "R.C"
3	DC-OK	High (3.5 ~ 5.5Vdc) : When the $V_{out} \leq 77\% \pm 5\%$. Low (-0.5 ~ 0.5Vdc) : When $V_{out} \geq 80\% \pm 5\%$. The maximum sourcing current is 10mA and only for output. (Note)
4,6	GND-AUX	Auxiliary voltage output GND. The signal return is isolated from the output terminals (+V & -V).
5	+12V-AUX	Auxiliary voltage output, 10.2~13.8Vdc, referenced to GND-aux. The maximum load current is 0.8A. This output has the built-in "Oring diodes" and is not controlled by "R.C".
7	D+	For MODBus model: Data line used in MODBus interface. (Note)
	CANH	For CANBus model: Data line used in CANBus interface. (Note)
8	D-	For MODBus model: Data line used in MODBus interface. (Note)
	CANL	For CANBus model: Data line used in CANBus interface. (Note)

Note: Isolated signal, referenced to GND-AUX.

4.5 Communication Address / ID Assignment

Each NSP-2400 unit must have a unique device address for bus communication. Configuration method is as follows: Connecting any of CN1 pins A0, A1, A2, or A3 to pin 11 or pin 12 (GND) sets that pin to logic 0. Leaving the pin unconnected sets it to logic 1. As shown in the table below, up to 16 address combinations (00-15) are available.

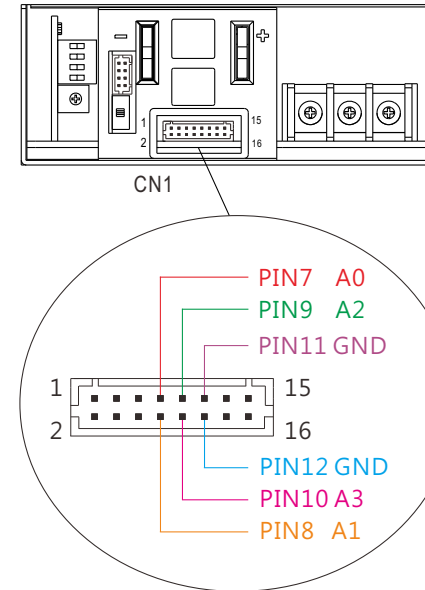

Module No.	Device address			
	A3	A2	A1	A0
	DIP switch position			
	10	9	8	7
00	0	0	0	0
01	0	0	0	1
02	0	0	1	0
03	0	0	1	1
04	0	1	0	0
05	0	1	0	1
06	0	1	1	0
07	0	1	1	1
08	1	0	0	0
09	1	0	0	1
10	1	0	1	0
11	1	0	1	1
12	1	1	0	0
13	1	1	0	1
14	1	1	1	0
15	1	1	1	1

5.Explanation of Operation

5.1 Peak Power

The NSP-2400 series can supply up to 200% peak power output. It can operate without triggering over-temperature or overload protection as long as the load conditions and duty cycle meet the following formula.

$$P_{av} = \frac{P_{pk} \times t + P_{npk} \times (T-t)}{T} \leq P_{rated}$$

$$\text{Duty} = \frac{t}{T} \times 100\% \leq 35\%$$

$t \leq 2$ sec (For 12V/15V models)

$t \leq 5$ sec (For other models)

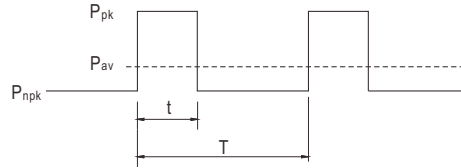

P_{av} : Average output power (W)	P_{rated} : Rated output power (W)
P_{pk} : Peak output power (W)	t: Peak power duration (sec)
P_{npk} : Non-peak output power (W)	T: Period (sec)

$$P_{pk} = P_{rated} \times \text{peak power capability (\%)}$$

Refer to the curve below for the peak power capability.

◎ 12V/15V

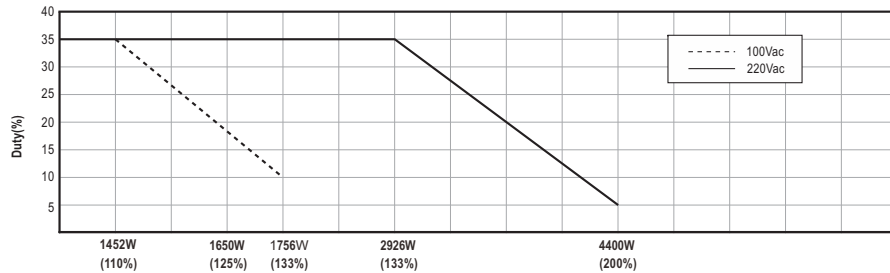

◎ Other models

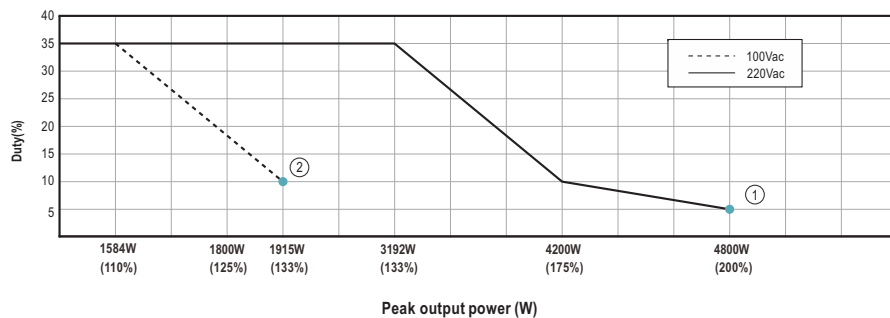

In the above curves,

- ① If the AC input is 220Vac and the peak power duty cycle is within 5%, the peak power capability is 200%. ($P_{pk} = 2,400W (P_{rated}) \times 200\% = 4,800W$)
- ② If the AC input is 100Vac and the peak power duty cycle is about 10%, the peak power capability is 133% ($P_{pk} = 2,400W (P_{rated}) \times 60\% \times 133\% = 1,915W$) (The output current derates to 60% of rated value at input voltage 100VAC. See Section 2.5)

Note.

1. Input ≥ 220 Vac: Maximum peak output power (P_{pk}) = 2 × rated power (P_{rated})
Input < 220 Vac: Maximum peak output power (P_{pk}) = 1.33 × rated power (P_{rated})
2. For 12V/15V models, the average output power (P_{av}) must not exceed 90% of the rated output power (P_{rated}).

Let's walk through two examples: one for the 12V/15V models and another for the remaining models.

1.12V/15V models

All calculations meet the requirements of the peak power formula in the following table.

$$P_{av} = \frac{4400 \times 2 + 1853 \times (40 - 2)}{40} = 1980W (\leq 90\% \times P_{rated} = 1980W)$$

$$\text{Duty} = \frac{2}{40} \times 100\% = 5\% (\leq 5\%)$$

$t = 2$ sec (≤ 2 sec)

2.Other models

All calculations meet the requirements of the peak power formula in the following table.

$$P_{av} = \frac{4800 \times 5 + 2274 \times (100 - 5)}{100} = 2400W (\leq P_{rated} 2400W)$$

$$\text{Duty} = \frac{5}{100} \times 100\% = 5\% (\leq 5\%)$$

$t = 5$ sec (≤ 5 sec)

Model	12V/15V	Other models
P_{pk}	4400W	4800W
P_{av}	1980W	2400W
Duty_max	5%	5%
t	$t \leq 2$	$t \leq 5$
T	$T \geq \frac{2\text{sec}}{5\%} = 40\text{sec}$	$T \geq \frac{5\text{sec}}{5\%} = 100\text{sec}$
$P_{npk} \leq \frac{T \times P_{av} - t \times P_{pk}}{T - t}$	1853W	2274W

5.2 Inrush Current Limiting

- Since the inrush current limit circuit mainly consists of a thermistor and a relay, inrush current will be much higher than the specified value if input thermistor is not allowed sufficient time to cool down. After turning OFF the unit, a 10 second cool down period is recommended before turning ON again.

5.3 Power Factor Correction (PFC)

- Built-in active power factor correction (PFC) circuit. The power factor (PF) is greater than 0.98 at 115Vac full load and 0.95 or above at 230Vac full load. PF may fall below 0.95 when input voltage exceeds 230Vac or output is below full load.

5.4 DIP Switch Function Overview

- The NSP-2400 can enable specific functions via DIP switch SW1 (Pin 1 to Pin 4). Refer to the table below for functional mapping.

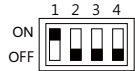
Icon	Pin No.	Description	Default
	1	Overload protection (OLP) type selection. Refer to Section 5.5 for details.	ON
	2	Output Current Programming (P.C) enable/disable. Refer to Section 5.7 for details.	OFF
	3	Output Voltage Programming (P.V) enable/disable. Refer to Section 5.6 for details.	OFF
	4	Termination resistor for parallel operation. Refer to Section 5.8 for details.	OFF

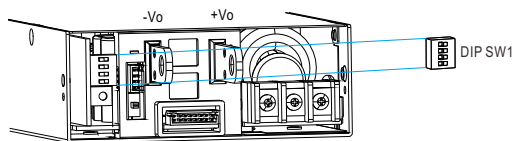

- Refer to the table below for the combined functions of DIP switch SW1 (Pin 1 and Pin 2).

Case	Pin 1 (OLP)	Pin 2 (PC)	Power Capability	Overload Protection (OLP)	Short Circuit Protection (SCP)
1 (Default)	ON	OFF	200%	>105% rated: Maintains operation state with delay shutdown after 5 seconds. (Note 1) >200% rated: Constant current limiting at 200%~205% of rated current with delay shutdown after 5 seconds. ※ For 12V/15V models, the protection delay time is 2seconds.	Constant current limiting at 200%~205% of rated current with delay shutdown after 5 seconds. ※ For 12V/15V models, the protection delay time is 2seconds.
2	OFF	OFF	105%	Constant current limiting at 105%~110% rated load without shutdown .	Constant current limiting at 105%~110% rated load without shutdown . (Note 2)
3	ON	ON	Set by PC	Constant current limiting at user-defined value with delay shutdown after 5 seconds.	Constant current limiting at user-defined value with delay shutdown after 5 seconds. (Note 2)
4	OFF	ON	Set by PC	Constant current limiting at user-defined value without shutdown .	Constant current limiting at user-defined value without shutdown . (Note 2)

Note 1. For instance, if the load reaches 130% of the rated current, the device continues operating under this condition without voltage degradation for 5 seconds before the overload protection is activated.

Note 2. A short circuit occurring under stabilized output voltage may trigger protective shutdown.

Note 3. Communication control for output current adjustment (see Section 5.7) is functionally equivalent to setting DIP SW1 Pin 2 to ON.

Note 4. Refer to Section 7.1 for detailed protection specifications.

5.5 Overload Protection (OLP) Type Selection

Overload protection can be set in the following 2 modes.

Power cycle the unit for the changes to take effect.

- (1) Constant current limiting with delay shutdown after 5 seconds (2 seconds for 12V/15V models). Power cycle the unit to recover.
- (a) Set DIP SW1 pin 1 as shown in the figure on the right. This is the factory default setting.



- (b) Peak power capability is enabled. (See Section 5.1.)
- (2) Constant current limiting.
- (a) Set DIP SW1 pin 1 as shown in the figure on the right.
- (b) Peak power capability is disabled.

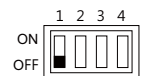

5.6 Output Voltage Adjustment

- Output voltage can be adjusted via SVR, PV and communication interface. The priority order is: communication > PV > SVR. When a higher priority method is active, lower priority methods are overridden.
- When the output voltage is set above the rated voltage, a corresponding decrease in output current is required. The output power should not exceed the rated value under any circumstance.

5.6.1 SVR

A. Set DIP SW1 pin 3 as shown below.



B. Output voltage can be trimmed by the SVR, as shown in the figure below. The adjustment range is specified in the table below.

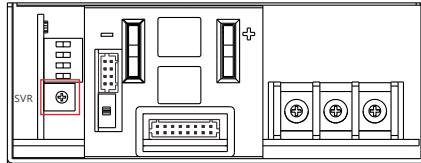

Model	Adjustment Range	Model	Adjustment Range
12V	10.8~14.4V	36V	32.4~43.2V
15V	13.5~19.0V	48V	43.2~55.0V
24V	21.6~28.8V	60V	54.0~72.0V
27V	24.3~32.4V		

5.6.2 PV (Output Voltage Programming)

A. Set DIP SW1 pin 3 as shown below to enable the PV function.

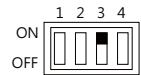

B. Connect an external DC voltage to PV and GND, as shown in the figure below.

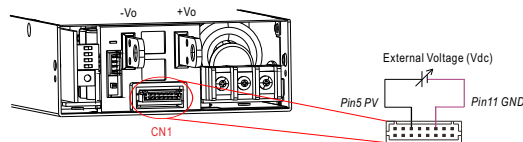

C. Relationship between output voltage and external DC voltage is shown in the curve below.

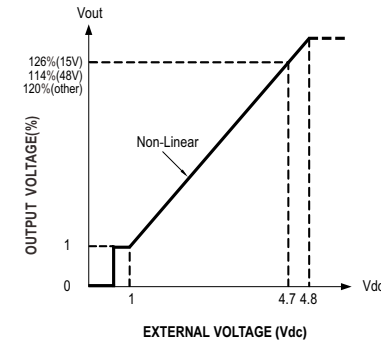

Note.

1. The recommended external voltage is 0~5VDC. Exceeding this range may damage the PSU.
2. The PSU may turn off its output when the external voltage falls below 0.3~0.5VDC.

5.6.3 Communication

Output voltage can be adjusted through CAN bus/Modbus interface. Refer to Chapter 6 for details.

5.7 Output Current Adjustment

- Output current can be adjusted via PC (Output Current Programming) and communication interface. The priority order is: communication > PC. When a higher priority method is active, lower priority methods are overridden.

5.7.1 P.C (Output Current Programming)

A. Default setting is at Overload Protection (OLP) value.



B. Set DIP SW1 pin 2 as shown below to enable the PC function.



C. Connect an external DC voltage to PC and GND, as shown in the figure below.

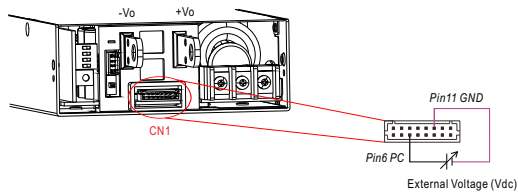

D. Relationship between output current and external DC voltage is shown in the figure below.

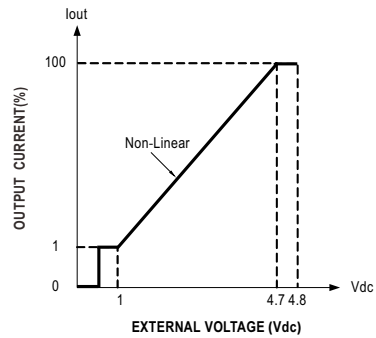

Note.

1. The recommended external voltage is 0~5VDC. Exceeding this range may damage the PSU.
2. The PSU may turn off its output when the external voltage falls below 0.3~0.5VDC.

5.7.2 Communication

Output current can be adjusted through CAN bus/Modbus interface. Refer to Chapter 6 for details.

5.8 Parallel Function

5.8.1 Termination Resistor Setting

(1) Non-parallel operation

Set DIP SW1 pin 4 as shown below. This is the factory default setting.

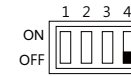

(2) Parallel operation

When parallel function is used, only the first and last PSUs need to have DIP SW1 pin 4 set to ON as shown below to reduce signal reflections on the parallel bus.

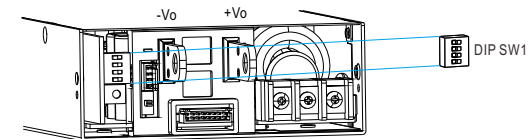
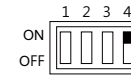

5.8.2 Parallel Operation Instructions

NSP-2400 has the built-in active current sharing function and can be connected in parallel, up to 4 units, to provide higher output power as exhibited below :

- ⊙ The power supplies should be paralleled using short and large diameter wiring and then connected to the load.
- ⊙ Difference of output voltages among parallel units should be less than 0.2Vdc.
- ⊙ The total output current must not exceed the value determined by the following equation:
Maximum output current at parallel operation = (Rated current per unit) × (Number of unit) × 0.9
- ⊙ Under parallel operation, the minimum output load should be greater than 5% of total output load; otherwise, it is likely that only one unit operates whereas other units may enter standby mode or their LED status indicators may not turn on.
- ⊙ When the total output current is less than 5% of the total rated current, or say (5% of Rated current per unit) × (Number of unit) the current shared among units may not be fully balanced.
- ⊙ For parallel operation requirements with an output voltage below 1.5V, Please contact the Mean Well technical service team.
- ⊙ CN1/SW1 Function pin connection

Parallel	PSU1		PSU2		PSU3		PSU4	
	CN1	SW1 Pin4	CN1	SW1 Pin4	CN1	SW1 Pin4	CN1	SW1 Pin4
1 unit	X	ON	—	—	—	—	—	—
2 unit	✓	ON	✓	ON	—	—	—	—
3 unit	✓	ON	✓	—	✓	ON	—	—
4 unit	✓	ON	✓	—	✓	—	✓	ON

⊙ ✓ is CN1/DIP SW1 connected to plug pin, X is CN1/DIP SW1 not connected to plug pin.

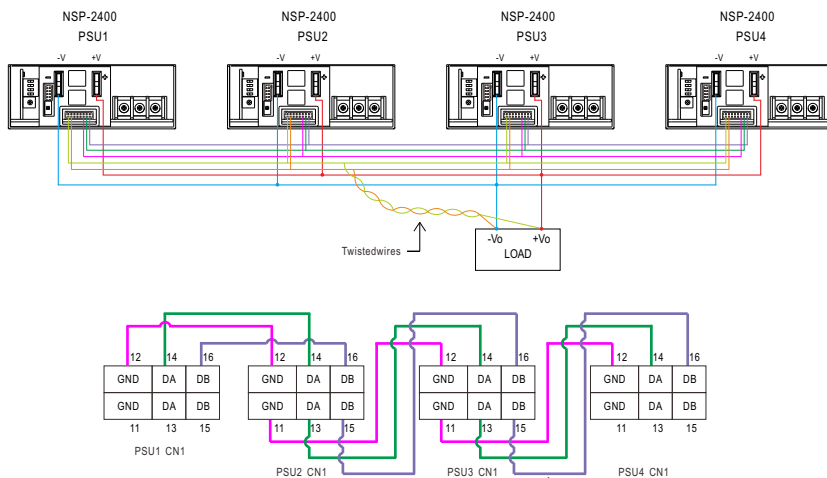

For longer CN1 cable lengths, twisted-pair wiring is recommended to minimize noise interference

5.9 Remote Control

- The power supply can be turned ON/OFF individually or along with other units by using the "Remote Control" function with external switch, photocoupler or relay.

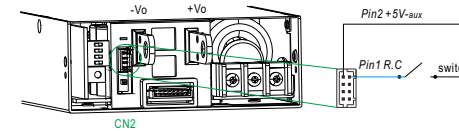

PSU Vo Status	Between +5V-aux(Pin 2) and R.C(Pin 1)
Power ON	Switch Short
Power OFF	Switch Open

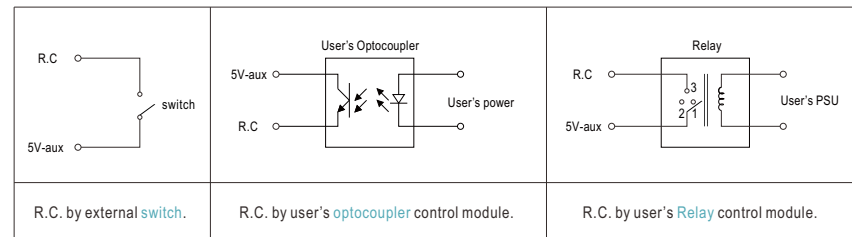

5.10 Voltage Drop Compensation (Remote Sense/Local Sense)

- Remote Sense

The Remote Sense compensates voltage drop on the load wiring up to 0.5Vdc

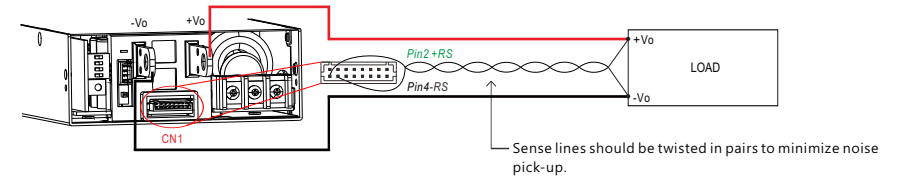

- ⊙ The +RS signal should be connected to the positive terminal of the load whereas -RS signal to the negative terminal

- Local Sense

The +RS,-RS have to be connected to the +Vo(signal), -Vo(signal), respectively, as the following diagram, in order to get the correct output voltage if Remote Sense is not used.

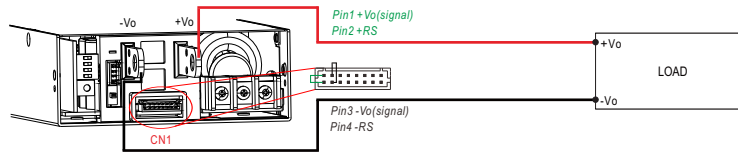

5.11 Output Voltage Signal ($\overline{\text{DC-OK}}$)

- Built-in DC output voltage detection circuit.
- Maximum output current 10mA.

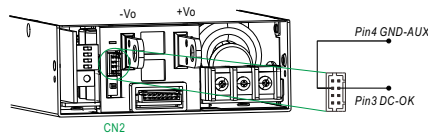

DC Output Status	$\overline{\text{DC-OK}}$ to GND-aux
Abnormal ($V_o \geq 80\% \pm 5\%$)	-0.5 ~ 0.5 Vdc
Normal ($V_o \leq 77\% \pm 5\%$)	3.5 ~ 5.5 Vdc

5.12 Auxiliary Output

- Built-in 12Vdc/0.8A and 5Vdc/0.2A auxiliary outputs.

+12V-AUX to GND-AUX	12Vdc / 0.8A
+5V-AUX to GND-AUX	5Vdc / 0.2A

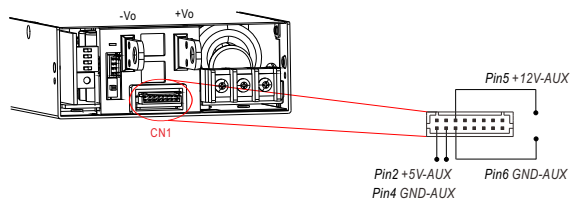

5.13 Fan Speed Control

- Built-in fan speed control circuit, fan speed changes automatically depending on internal temperature.

5.14 Factory Resetting

Users can follow the steps below to restore factory settings for these commands:

- CAN bus Model: 0x0000, 0x0020, 0x0030, and 0x00C2, 0x00C3.
 - Modbus Model: 0x0000, 0x0020, 0x0030, and 0x00C4, 0x00C5.
- Turn off the AC power and short each Address pin (A0~A3) to GND (PIN 11 or PIN 12).
 - Turn on the AC power in REMOTE OFF mode (no output at this step).
 - Within 15 seconds of turning on AC power, change all Address pins (A0~A3) from "shorted" to "open," then back to "shorted."
 - Green LED will blink 3 times if set successfully. Turn off the AC power and wait for the LED to turn off. Then turn on the AC power again. The unit has now been successfully reset to factory default settings.
 - If the EEPROM storage function was DISABLE (high byte bit 2 set to "logic 1" in SYSTEM_CONFIG (CAN bus: 0x00C2 / Modbus: 0x00C4), please perform step ① - ④ again to fully restore the parameters back to factory settings.

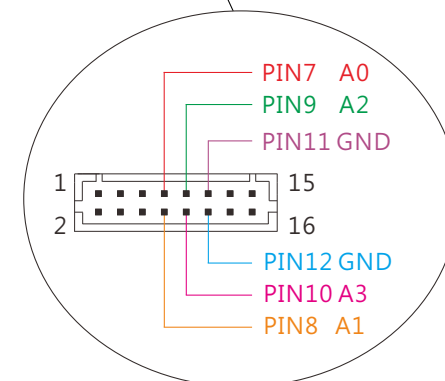
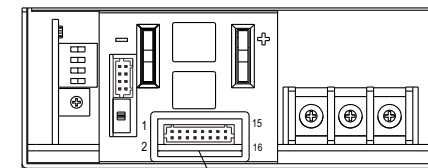

6.Communication Protocol

- There are two means to control the power supply, analog signals and digital communication. Analog is the default setting for the supply, signals including PV, PC, and SVR can be used immediately once receiving the supply. The digital communication of CAN bus / Modbus is initially uncontrollable but readable. To activate the digital communication, please set CAN_CTRL / MOD_CTRL of SYSTEM_CONFIG (CAN bus: 0x00C2 / Modbus: 0x00C4) at "1". Once the digital communication dominates the supply, the analog signals become invalid. Refer to Section 6.1.2 for CAN bus command list. Refer to Section 6.2.5 for Modbus command list.

Note:

- At default setting of analog, the following commands are invalid but can be written while other commands are effective: OPERATION (0x0000), VOUT_SET (0x0020), and IOOUT_SET (0x0030).
- All written parameters of commands: 0x0000, 0x0020 and 0x0030 are saved into EEPROM and take effect after the digital is activated.

6.1 CAN bus Protocol

- Physical layer specification

This protocol follows CAN ISO-11898 with Baud rate of 250Kbps.

- Data Frame

This protocol uses Extended CAN 29-bit identifier frame format or CAN2.0B.

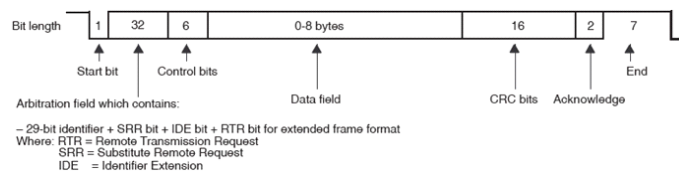

- Communication Timing

Min. request period (Controller to NSP-2400): 50mSec ◦

Max. response time (NSP-2400 to Controller): 12.5mSec ◦

Min. packet margin time (Controller to NSP-2400): 12.5mSec ◦

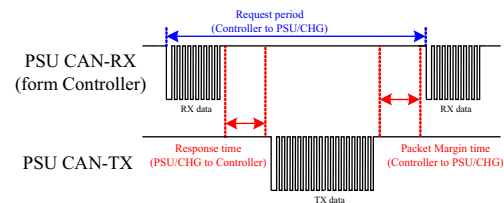

- Data Field Format (Refer to Section 6.1.3 for communication examples)

Controller to NSP-2400

Write:

Data filed bytes



Read:

Data filed bytes



NSP-2400 to Controller

Response:

Data filed bytes



NOTE: NSP-2400 will not send data back when writing parameters, such as VOUT_SET

6.1.1 Message ID definition

Message ID	Description
0x000C00XX	NSP-2400 to Controller Message ID
0x000C01XX	Controller to NSP-2400 Message ID
0x000C01FF	Controller broadcasts to NSP-2400

Note: XX means the address of NSP-2400. Refer to Section 4.5 for Communication Address / ID Assignment.

6.1.2 CAN bus Command list

Command Code	Command Name	Transaction Type	# of data Bytes	Description
0x0000	OPERATION	R/W	1	ON/OFF control ON: 01h / OFF: 00h
0x0020	VOUT_SET*	R/W	2	Output voltage set (Factor=0.01)
0x0030	IOUT_SET*	R/W	2	Output current set (Factor=0.01)
0x0040	FAULT_STATUS	R	2	Abnormal status
0x0050	READ_VIN	R	2	Input voltage read value (Factor=0.1)
0x0060	READ_VOUT	R	2	Output voltage read value (Factor=0.01)
0x0061	READ_IOUT	R	2	Output current read value (Factor=0.01)
0x0062	READ_TEMPERATURE_1	R	2	Internal ambient temperature (Factor=0.1)
0x0070	READ_FAN_SPEED_1	R	2	Fan speed 1 reading value (Factor=1)
0x0071	READ_FAN_SPEED_2	R	2	Fan speed 2 reading value (Factor=1)
0x0080	MFR_ID_B0B5	R	6	Manufacturer's name (first 6 digits)
0x0081	MFR_ID_B6B11	R	6	Manufacturer's name (last 6 digits)
0x0082	MFR_MODEL_B0B5	R	6	Manufacturer's model name (first 6 digits)
0x0083	MFR_MODEL_B6B11	R	6	Manufacturer's model name (last 6 digits)
0x0084	MFR_REVISION_B0B5	R	6	Firmware version
0x0085	MFR_LOCATION_B0B2	R/W	3	Manufacturer's factory location
0x0086	MFR_DATE_B0B5	R/W	6	Manufacture date
0x0087	MFR_SERIAL_B0B5	R/W	6	Product serial number (first 6 digits)
0x0088	MFR_SERIAL_B6B11	R/W	6	Product serial number (last 6 digits)
0x00C0	SCALING_FACTOR	R	6	Scaling ratio
0x00C1	SYSTEM_STATUS	R	2	System status
0x00C2	SYSTEM_CONFIG	R/W	2	System configuration
0x00C3	PROTECT_CONFIG	R/W	2	Protect Configuration
0x0910	CLEAR_LOG	W	2	Clear Event Log
0x0921	EVENT_0	R	2	Latest Event Log
0x0922	EVENT_1	R	2	Previous Event Log
0x0923	EVENT_2	R	2	2 nd Previous Event Log
0x0924	EVENT_3	R	2	3 rd Previous Event Log
0x0925	EVENT_4	R	2	4 th Previous Event Log

Note. Setting command with * at the end support the EEP_OFF and EEP_CONFIG functions.
Refer to SYSTEM_CONFIG (0x00C2) for detailed information on how to enable them.

Data conversion:

The conversion for setting and reading values is defined as following:
Actual value = Communication read value × Factor, where the factor value is used for both writing and reading during communication for data conversion. Each command may have a different factor value, which can be found in the command list or retrieved from the SCALING_FACTOR (0x00C0) command.

EX: V_{o_real} (actual DC voltage) = READ_VOUT × Factor.

If the Factory of READ_VOUT of a certain mode is 0.01, the communication reading value is 0x0960(hexadecimal) → 2400(decimal), then $VDC_{real} = 2400 \times 0.01 = 24.0V$.

©FAULT_STATUS(0x0040) :

	Bit7	Bit6	Bit5	Bit4	Bit3	Bit2	Bit1	Bit0
High byte	-	-	-	-	-	-	UTP	-
Low byte	HI_TEMP	OP_OFF	AC_FAIL	SHORT	OLP	OVP	OTP	FAN_FAIL

Low byte

Bit 0 FAN_FAIL : Fan locked flag

- 0 = Working normally
- 1 = Fan locked

Bit 1 OTP : Over temperature protection

- 0 = Internal temperature normal
- 1 = Internal temperature abnormal

Bit 2 OVP : DC over voltage protection

- 0 = DC voltage normal
- 1 = DC over voltage protected

Bit 3 OLP : DC over current protection

- 0 = DC current normal
- 1 = DC over current protected

Bit 4 SHORT : Short circuit protection

- 0 = Shorted circuit do not exist
- 1 = Shorted circuit protected

Bit 5 AC_FAIL : AC abnormal flag

- 0 = AC input range normal
- 1 = AC input range abnormal

Bit 6 OP_OFF : DC status

- 0 = DC output turned on
- 1 = DC output turned off

Bit 7 HI_TEMP : Internal high temperature alarm
 0 = Internal temperature normal
 1 = Internal temperature abnormal

High byte

Bit 1 UTP : Under temperature protection
 0 = Internal temperature normal
 1 = Internal temperature abnormal

Note: Unsupported settings displays with "0"

©MFR_ID_B0B5 (0x0080) is the first 6 codes of the manufacturer's name (ASCII);
 MFR_ID_B6B11 (0x0081) is the last 6 codes of the manufacturer's name (ASCII)
 EX: Manufacturer's name is MEANWELL MFR_ID_B0B5 is MEANWE ;
 MFR_ID_B6B11 is LL

MFR_ID_B0B5					
Byte 0	Byte 1	Byte 2	Byte 3	Byte 4	Byte 5
0x4D	0x45	0x41	0x4E	0x57	0x45

MFR_ID_B6B11					
Byte 0	Byte 1	Byte 2	Byte 3	Byte 4	Byte 5
0x4C	0x4C	0x20	0x20	0x20	0x20

©MFR_MODEL_B0B5 (0x0082) is the first 6 codes of the manufacturer's model name (ASCII); MFR_MODEL_B6B11 (0x0083) is the last 6 codes of the manufacturer's model name (ASCII)
 EX: Model names is NSP-2400-48 → MFR_MODEL_B0B5 is NSP-24 ;
 MFR_MODEL_B6B11 is 00-48

MFR_MODEL_B0B5					
Byte 0	Byte 1	Byte 2	Byte 3	Byte 4	Byte 5
0x4E	0x53	0x50	0x2D	0x32	0x34

MFR_ID_B6B11					
Byte 6	Byte 7	Byte 8	Byte 9	Byte 10	Byte 11
0x30	0x30	0x2D	0x34	0x38	0x20

©MFR_REVISION_B0B5 (0x0084) is the firmware revision (hexadecimal).
 A range of 0x00 (R00.0)~0xFE (R25.4) represents the firmware version of an MCU;
 0xFF represents no MCU existed.
 EX: The supply has two MCUs, the firmware version of the MCU number 1 is version R01.3 (0x0D), the MCU number 2 is version R01.2 (0x0C)

Byte 0	Byte 1	Byte 2	Byte 3	Byte 4	Byte 5
0x0D	0x0C	0xFF	0xFF	0xFF	0xFF

©MFR_DATE_B0B5 (0x0086) is manufacture date (ASCII)
 EX: MFR_DATE_B0B5 is 250101, meaning 2025/01/01

Byte 0	Byte 1	Byte 2	Byte 3	Byte 4	Byte 5
0x32	0x35	0x30	0x31	0x30	0x31

©MFR_SERIAL_B0B5 (0x0087) and MFR_SERIAL_B6B11 (0x0088) are defined as manufacture date and manufacture serial number (ASCII)
 EX: The 31st unit manufactured on 2025/1/1 MFR_SERIAL_B0B5 is 250101; MFR_SERIAL_B6B11 is 000031

MFR_ID_B0B5					
Byte 0	Byte 1	Byte 2	Byte 3	Byte 4	Byte 5
0x32	0x35	0x30	0x31	0x30	0x31

MFR_ID_B6B11					
Byte 0	Byte 1	Byte 2	Byte 3	Byte 4	Byte 5
0x30	0x30	0x30	0x30	0x33	0x31

©SCALING_FACTOR (0x00C0) :

Bit7~Bit0								
byte4~5	Reserved							
	Bit7	Bit6	Bit5	Bit4	Bit3	Bit2	Bit1	Bit0
byte3	Reserved			Reserved				
	Bit7	Bit6	Bit5	Bit4	Bit3	Bit2	Bit1	Bit0
byte2	Reserved			TEMPERATURE_1 Factor				
	Bit7	Bit6	Bit5	Bit4	Bit3	Bit2	Bit1	Bit0
byte1	FAN_SPEED Factor			VIN Factor				
	Bit7	Bit6	Bit5	Bit4	Bit3	Bit2	Bit1	Bit0
byte0	IOUT Factor			VOUT Factor				

byte0:

Bit 0:3 VOUT Factor : The factor of output voltage
 0x0=Output voltage relevant commands not supported
 0x4=0.001
 0x5=0.01
 0x6=0.1
 0x7=1.0
 0x8=10
 0x9=100

Bit 4:7 IOUT Factor : The Factor of DC current
 0x0=Output current relevant commands not supported
 0x4=0.001
 0x5=0.01
 0x6=0.1
 0x7=1.0
 0x8=10
 0x9=100

byte1:
 Bit 0:3 VIN Factor : The Factor of AC input voltage
 0x0=AC input relevant commands not supported
 0x4=0.001
 0x5=0.01
 0x6=0.1
 0x7=1.0
 0x8=10
 0x9=100

Bit 4:7 FAN_SPEED Factor : The Factor of fan speed
 0x0=Fan speed relevant commands not supported
 0x4=0.001
 0x5=0.01
 0x6=0.1
 0x7=1.0
 0x8=10
 0x9=100

byte2:
 Bit 0:3 TEMPERATURE_1 Factor : The Factor of internal ambient temperature
 0x0=internal ambient temperature relevant commands not supported
 0x4=0.001
 0x5=0.01
 0x6=0.1
 0x7=1.0
 0x8=10
 0x9=100

◎SYSTEM_STATUS(0x00C1) :

	Bit7	Bit6	Bit5	Bit4	Bit3	Bit2	Bit1	Bit0
High byte	-	-	-	-	OLP_MODE		-	RC
Low byte	-	EEPER	INITIAL-STATE	ADL_ON	ORING-OFF	PFC_OK	DC_OK	M/S

Low byte
 Bit 0: M/S : Parallel mode status
 0 = Current device is Slave
 1 = Current device is Master

Bit 1 DC_OK : Secondary DD output voltage status
 0 = Secondary DD output voltage status TOO LOW
 1 = Secondary DD output voltage status NORMAL

Bit 2: PFC_OK : Primary PFC status
 0 = Primary PFC OFF or abnormal
 1 = Primary PFC ON normally

Bit 3: ORING_OFF :
 0 = Disable ORING MOS after Secondary DD turn ON
 1 = Enable ORING MOS after Secondary DD turn ON

Bit 4 ADL_ON : Active dummy load control status
 0 = Active dummy load off/function not supported
 1 = Active dummy load on

Bit 5 INITIAL_STATE : Device initialized status
 0 = NOT in initialization status
 1 = In initialization status

Bit 6 EEPER : EEPROM data access error
 0 = EEPROM data access normal
 1 = EEPROM data access error

Note. When EEPROM data is corrupted, the PSU will shut down and enter protection mode. The PSU will restart only after the issue is resolved and the unit is power cycled. °

High Byte:
 Bit 0: RC: Remote ON/OFF state
 0 = Remote OFF
 1 = Remote ON

Bit 2:3 OLP_MODE: Overload Protection (OLP) mode status
 0b00 = Constant current limiting with a 5-second delayed shutdown during overload(2 sec for 12V/15V model)
 0b01 = Continuous constant current limiting during overload
 0b10 = Reserved
 0b11 = Reserved

Note: Unsupported settings displays with "0"

◎SYSTEM_CONFIG(0x00C2) :

	Bit7	Bit6	Bit5	Bit4	Bit3	Bit2	Bit1	Bit0
High byte	-	-	-	-	-	EEP_OFF	EEP_CONFIG	
Low byte	-	-	-	-	-	OPERATION_INIT		CAN_CTRL

Low byte:

Bit 0 CAN_CTRL : CAN bus communication control status
 0 = The output voltage/current defined by control over SVR/PV/PC (factory default)
 1 = The output voltage, current, ON/OFF control defined by control over CAN bus (VOUT_SET, IOUT_SET, OPERATION)

Bit 1:2 OPERATION_INIT : Pre-set value of power on operation command
 0b00 = Power OFF, pre-set 0x00(OFF)
 0b01 = Power ON, pre-set 0x01(ON) (factory default)
 0b10 = Pre-set is previous set value
 0b11 = Not used, reserved

High Byte:

Bit 0:1 EEP_CONFIG: EEPROM Configuration
 0b00 = Immediate. Changes to parameters are written to EEPROM immediately (factory default)
 0b01 = 1 minute delay. Write changes to EEPROM if all parameters remain unchanged for 1 minute
 0b10 = 10 minute delay. Write changes to EEPROM if all parameters remain unchanged for 10 minutes
 0b11 = Reserved

Bit 2 EEP_OFF: EEPROM storage function ON/OFF
 0 = Enable. Parameters to be saved into EEPROM (factory default)
 1 = Disable. Parameters NOT to be saved into EEPROM

Note: Unsupported settings display with "0"

◎PROTECT_CONFIG(0x00C3) :

	Bit7	Bit6	Bit5	Bit4	Bit3	Bit2	Bit1	Bit0
High byte	-	-	-	-	-	-	-	-
Low byte	-	-	-	-	-	-	-	OLP_TYPE

Low byte:

Bit 0 OLP_TYPE: OLP Configuration

0 = Constant current limiting with a 5-second delayed shutdown during overload (2 sec for 12V/15V model)

1 = Continuous constant current limiting during overload

Note: Unsupported settings displays with "0"

◎CLEAR_LOG (0x0910): The command clears the data stored in EVENT_0 to EVENT_4 (0x0921-0x0925). Event log data is stored in the EEPROM and remains intact after power off. To clear the event logs, write 0x00AA to CLEAR_LOG (0x0910).

For example, to clear the event logs for the PSU at Address 00, the command format is as follows:

CAN ID	DLC (data length)	Command code	Parameters
0x000C0100	0x4	0x1009	0xAA00

Command code: 0x0910(CLEAR_LOG) → 0x10 (Lo) + 0x09 (Hi)

Parameters: 0x00AA → 0xAA (Lo) + 0x00 (Hi)

◎EVENT_0 to EVENT_4 (0x0921-0x0925): Sequentially store the five most recent event logs. Refer to the table below for the mapping between event codes and their corresponding conditions.

Commands	Event (Decimal)	Event (Hexadecimal)	Event Description
EVENT_0 (0x0921) EVENT_1 (0x0922) EVENT_2 (0x0923) EVENT_3 (0x0924) EVENT_4 (0x0925)	0001	0x0001	Overload Protection (OLP)
	0002	0x0002	Over Voltage Protection (OVP)
	0006	0x0006	Short Circuit Protection (SCP)
	4001	0x0FA1	Over Temperature Protection (OTP)
	4002	0x0FA2	Under Temperature Protection (UTP)
	4004	0x0FA4	Fan Fail Protection
	4005	0x0FA5	Hardware Error
	4006	0x0FA6	Internal communication error
	4007	0x0FA7	EEPROM Error

The latest event is always stored in EVENT_0 (0x0921), and the remaining events are shifted accordingly from EVENT_1 (0x0922) to EVENT_4 (0x0925). When the number of events exceeds five, the oldest event is discarded from the event log. Refer to the table below for the sequence of events and data shifting logic.

Timing/Event	T1 (Earliest)	T2	T3	T4	T5	T6 (Latest)
Command	Fan Fail	OTP	SCP	OLP	OVP	OLP
EVENT_0 (0x0921)	4004	4001	0006	0001	0002	0001
EVENT_1 (0x0922)	0	4004	4001	0006	0001	0002
EVENT_2 (0x0923)	0	0	4004	4001	0006	0001
EVENT_3 (0x0924)	0	0	0	4004	4001	0006
EVENT_4 (0x0925)	0	0	0	0	4004	4001
Remark	4004 stored in EVENT_0	4001 stored in EVENT_0; existing logs shift	0006 stored in EVENT_0; existing logs shift	0001 stored in EVENT_0; existing logs shift	0002 stored in EVENT_0; existing logs shift	0001 stored in EVENT_0; existing logs shift; 4004 pushed out

6.1.3 Communication Examples

The following provides example of command sending and data reading for the CAN bus protocol.

6.1.3.1 Sending Command

The master adjusts output voltage of the unit with address "01" to 30V.

CAN ID	DLC (data length)	Command code	Parameters
0x000C0101	0x4	0x2000	0xB80B

Command code: 0x0020 (VOUT_SET) → 0x20(Lo) + 0x00(Hi)

Parameters: 30V → 3000 → 0x0BB8 → 0xB8(Lo) + 0x0B(Hi)

Note: Conversion factor for VOUT_SET is 0.01, so $\frac{30V}{F=0.01} = 3000$

6.1.3.2 Reading Data or Status

The master reads operation setting from the unit with address "00".

CAN ID	DLC (data length)	Command code
0x000C0100	0x2	0x0000

The unit with address "00" returns data below:

CAN ID	DLC (data length)	Command code	Parameters
0x000C0000	0x3	0x0000	0x01

Parameters: 0x01 ON, meaning that the unit with address "00" is operating.

6.1.3.3 Practical Operation

The following steps will describe how to set the NSP-2400-24 to 20V.

1. Set the ID of the power supply to "0". Connect the A0(PIN 7), A1(PIN 8), A2(PIN 9), and A3(PIN 10) to GND(PIN 11 or PIN 12), all on the CN1.

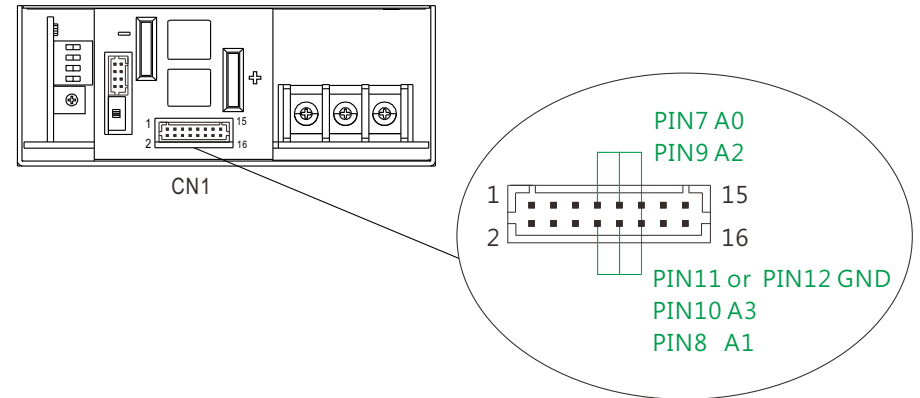

2. Connect the CANH/CANL pins of the master to the corresponding CANH (PIN 7) and CANL (PIN 8) pins of the CN2 connector on the power supply. It is recommended to establish a common ground for the communication system to increase its communication reliability by using GND-AUX (PIN 4 or PIN 6) of CN2.

- ⊙ Set baud rate: 250kbps, type: extended
- ⊙ Adding a 120Ω terminal resistor to both the controller and power supply ends can increase communication stability.
- ⊙ For units configured as a bus terminal, the termination resistor should be enabled by setting SW2 to ON.

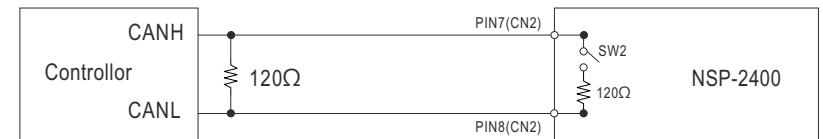

3. Configure communication settings after power on. Enable communication mode and set power ON when AC connected.

CAN ID	DLC (data length)	Command Code	Parameters
0x000C0100	0x04	0xC200	0x0300

Command code: 0x00C2 (SYSTEM_CONFIG)

Data: 03(Lo) + 00(Hi) • Please refer to definition of SYSTEM_CONFIG for detailed information.

4. Set output voltage to 20V.

CAN ID	Operation	Command Code	Data
0x00C0100	0x04	0x2000	0xD007

Command code: 0x0020 (VOUT_SET) → 0x20 (Lo) + 0x00 (Hi),

Data: 20V → 2000 → 0x07D0 → 0xD0 (Lo) + 0x07 (Hi);

Note. Conversion factor for VOUT_SET is 0.01, so $\frac{20V}{F=0.01} = 2000$

5. It is recommended to review all of the settings and parameters using the appropriate commands. In the event that they do not meet your requirements, you may rewrite them as needed. EX: Read VOUT_SET to check whether output voltage was set to a proper level.

Read VOUT_SET

CAN ID	Operation	Command Code
0x00C0100	0x02	0x2000

The unit returns data below

CAN ID	Operation	Command Code	Parameters
0x00C0000	0x04	0x2000	0xD007

Data: 0xD0 (Lo) + 0x07 (Hi) → 0x7D0 → 2000 = 20V ◦

6. Finally, check whether R.C (PIN 1) and +5-AUX (PIN 2) pins of the CN2 connector are short-circuited if there is no output voltage.

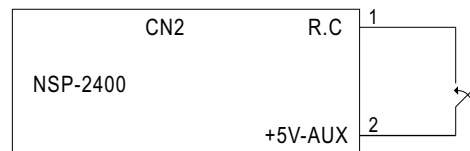

6.2 Modbus Communication Interface

The device supports Modbus RTU with the master-slave principle.

Users are able to read and write parameters of the device through the protocol, including remote ON/OFF, output voltage/current setting, etc. During data transfer, please follow the principle of first sending the Hi byte and then the Lo byte except Error Check (CRC16 checksum).

Physical Layer setting as below:

Control	Setting
Baud Rate	115200
Data Bits	8
Stop Bit	1
Parity	None
Flow Control	None

6.2.1 Communication Timing

Min. request period (Controller to PSU): 50mSec ◦

Max. response time (PSU to Controller): 12.5mSec ◦

Min. packet margin time (Controller to PSU): 12.5mSec ◦

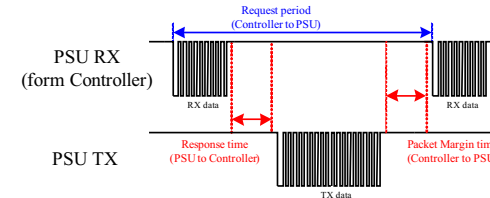

6.2.2 Modbus Frame Encapsulation

Modbus RTU consists of Additional Address, Function Code, Data and Error Check.

Additional Address	Function Code	Data	Error Check
1 byte	1 byte	N bytes	2 bytes

Additional address (1byte) : defines PSU/Charger slave ID.

Function code (1byte) : The function code is used to tell the slave what kind of action to perform.

Data (N bytes): For data exchange, contents and data length are dependent on different function codes.

Error Check (2bytes) : utilizes CRC-16.

6.2.3 Additional Address Definition

Additional address is the slave ID of the device. Each unit should have their unique and own device address to communicate over the bus.

Slave ID	Description
0x80 + 0xXX	XX means device address
0x00	Broadcast

Note: XX means the address of NSP-2400. Refer to Section 4.5 for Communication Address/ID Assignment.

For example, the Slave ID for a PSU with address 01 is 0x80 + 0x01 = 0x81.

6.2.4 Function Code Description

The main purpose of the function codes is to tell the slave what kind of action to perform. For example: Function code 03 will query the slave to read holding registers and respond with the master their contents.

Function Code		Depiction
Read Holding Register	0x03	Read Holding Register
Read Input Register	0x04	Read Input Register
Preset Single Register	0x06	Preset Single Register

6.2.5 Data Field and Command Lists

Data field provides additional information by the slave to complete the action specified by the function code(FC) in a request. The data field typically includes register addresses, count values, and written data. There are several forms according to the function codes.

FC = 03/04

Starting Address	Quantity of (Input) Registers
2 Bytes	2 Bytes

FC = 06

Register Address	Register Value
2 Bytes	2 Bytes

Command List

Register address	Command Name	Function code	# of data Bytes	Description
0x0000	OPERATION	0x03, 0x06	2	Remote ON/OFF control ON: 0x0001 / OFF: 0x0000
0x0020	VOUT_SET*	0x03, 0x06	2	Output voltage set(Factor=0.01)
0x0030	IOUT_SET*	0x03, 0x06	2	Output current set(Factor=0.01)
0x0040	FAULT_STATUS	0x03	2	Abnormal status
0x0050	READ_VIN	0x04	2	Input voltage read value(Factor=0.1)
0x0060	READ_VOUT	0x04	2	Output voltage read value(Factor=0.01)
0x0061	READ_IOUT	0x04	2	Output current read value(Factor=0.01)
0x0062	READ_TEMPERATURE_1	0x04	2	Internal ambient temperature read value(Factor=0.1)
0x0070	READ_FAN_SPEED_1	0x04	2	Fan speed 1 read value (Factor=1)
0x0071	READ_FAN_SPEED_2	0x04	2	Fan speed 2 read value (Factor=1)
0x0080	MFR_ID_B0B5	0x03	6	Manufacturer's name(first 6 digits)
0x0083	MFR_ID_B6B11	0x03	6	Manufacturer's name(first 6 digits)
0x0086	MFR_MODEL_B0B5	0x03	6	Manufacturer's model name (first 6 digits)
0x0089	MFR_MODEL_B6B11	0x03	6	Manufacturer's model name (last 6 digits)
0x008C	MFR_REVISION_B0B5	0x03	6	Firmware version
0x008F	MFR_LOCATION_B0B2	0x03	3	Manufacturer's factory location
0x0091	MFR_DATE_B0B5	0x03	6	Manufacturing date
0x0094	MFR_SERIAL_B0B5	0x03	6	Product serial number (first 6 digits)
0x0097	MFR_SERIAL_B6B11	0x03	6	Product serial number (last 6 digits)
0x00C0	SCALING_FACTOR	0x03	6	Scaling ratio
0x00C3	SYSTEM_STATUS	0x03	2	System status
0x00C4	SYSTEM_CONFIG	0x03, 0x06	2	System configuration
0x00C5	PROTECT_CONFIG	0x03, 0x06	2	Protection configuration
0x0910	CLEAR_LOG	0x06	2	Clear Event Log
0x0921	EVENT_0	0x03	2	Latest Event Log
0x0922	EVENT_1	0x03	2	Previous Event Log
0x0923	EVENT_2	0x03	2	2 nd Previous Event Log
0x0924	EVENT_3	0x03	2	3 rd Previous Event Log
0x0925	EVENT_4	0x03	2	4 th Previous Event Log

Note: Setting commands with * at the end support the EEP_OFF and EEP_CONFIG functions. Refer to SYSTEM_CONFIG (0x00C4) for detailed information on how to enable them.

Data conversion :

The conversion of setting and reading values is defined as following:

Actual value = Communication reading value × Factor, where the factor value is used for both writing and reading during communication for data conversion. Each command may have a different factor value, which can be found in the command list or retrieved from the SCALING_FACTOR (0x00C0) command.

EX: Vo_real (actual DC voltage) = READ_VOUT × Factor.

If the Factor of READ_VOUT of a certain model is 0.01, the communication reading value is 0x0960 (hexadecimal)→2400(decimal), then VDC_real = 2400 × 0.01 = 24.00V.

©FAULT_STATUS(0x0040) :

	Bit7	Bit6	Bit5	Bit4	Bit3	Bit2	Bit1	Bit0
High byte	-	-	-	-	-	-	UTP	-
Low byte	HI_TEMP	OP_OFF	AC_FAIL	SHORT	OLP	OVP	OTP	FAN_FAIL

Low byte

Bit 0 FAN_FAIL : Fan locked flag

0 = Fan working normally

1 = Fan locked

Bit 1 OTP : Over temperature protection

0 = Internal temperature normal

1 = Internal temperature abnormal

Bit 2 OVP : Output over-voltage protection

0 = Output voltage normal

1 = Output over voltage protected

Bit 3 OLP : Output over current protection

0 = Output current normal

1 = Output over-current protected

Bit 4 SHORT : Short circuit protection

0 = Shorted circuit do not exist

1 = Shorted circuit protected

Bit 5 AC_FAIL : AC abnormal flag

0 = AC range normal

1 = AC range abnormal

Bit 6 OP_OFF : DC status

0 = DC turned on

1 = DC turned off

Bit 7 HI_TEMP : Internal high temperature alarm

0 = Internal temperature normal

1 = Internal temperature abnormal

High byte

Bit 1 UTP : Under temperature protection

0 = Internal temperature normal

1 = Internal temperature abnormal

Note: Unsupported settings displays with "0"

©MFR_ID_B0B5 (0x0080 - 0x0082) is the first 6 codes of the manufacturer's name (ASCII); MFR_ID_B6B11(0x0083 - 0x0085) is the last 6 codes of the manufacturer's name (ASCII)

EX: manufacturer's name is MEANWELL → MFR_ID_B0B5 is MEANWE ; MFR_ID_B6B11 is LL

MFR_ID_B0B5					
Byte 0	Byte 1	Byte 2	Byte 3	Byte 4	Byte 5
0x4D	0x45	0x41	0x4E	0x57	0x45

MFR_ID_B6B11					
Byte 0	Byte 1	Byte 2	Byte 3	Byte 4	Byte 5
0x4C	0x4C	0x20	0x20	0x20	0x20

©MFR_MODEL_B0B5 (0x0086 - 0x0088) is the first 6 codes of the manufacturer's model name (ASCII); MFR_MODEL_B6B11(0x0089 - 0x008B) is the last 6 codes of the manufacturer's model name (ASCII)

EX: Model name is NSP-2400-48 → MFR_MODEL_B0B5 is NSP-24 ; MFR_MODEL_B6B11 is 00-48

MFR_MODEL_B0B5					
Byte 0	Byte 1	Byte 2	Byte 3	Byte 4	Byte 5
0x4E	0x53	0x50	0x2D	0x32	0x34

MFR_MODEL_B6B11					
Byte 6	Byte 7	Byte 8	Byte 9	Byte 10	Byte 11
0x30	0x30	0x2D	0x34	0x38	0x20

©MFR_REVISION_B0B5 (0x008C - 0x008E) is the firmware revision. A range of 0x00 hexadecimal (R00.0)~0xFE (R25.4) represents the firmware version of an MCU; 0xFF represents no MCU existed

EX: The supply has two MCUs, the firmware version of the MCU number 1 is version R01.3 (0x0D), the MCU number 2 is version R01.2 (0x0C)

MFR_REVISION_B0B5					
Byte 0	Byte 1	Byte 2	Byte 3	Byte 4	Byte 5
0x0D	0x0C	0xFF	0xFF	0xFF	0xFF

©MFR_DATE_B0B5 (0x0091 -0x0093) is manufacture date (ASCII)

EX: MFR_DATE_B0B5 is 250101, meaning 2025/01/01

MFR_DATE_B0B5					
Byte 0	Byte 1	Byte 2	Byte 3	Byte 4	Byte 5
0x32	0x35	0x30	0x31	0x30	0x31

©MFR_SERIAL_B0B5 (0x0094 -0x0096) and MFR_SERIAL_B6B11 (0x0097 -0x0099) are defined as manufacture date and manufacture serial number (ASCII)

EX: The 31st unit manufactured on 2025/01/01 → MFR_SERIAL_B0B5: 250101 ; MFR_SERIAL_B6B11: 000031

MFR_SERIAL_B0B5					
Byte 0	Byte 1	Byte 2	Byte 3	Byte 4	Byte 5
0x32	0x35	0x30	0x31	0x30	0x31

MFR_SERIAL_B6B11					
Byte 0	Byte 1	Byte 2	Byte 3	Byte 4	Byte 5
0x30	0x30	0x30	0x30	0x33	0x31

©SCALING_FACTOR (0x00C0) :

Bit7~Bit0								
byte4~5	-----							
	Bit7	Bit6	Bit5	Bit4	Bit3	Bit2	Bit1	Bit0
byte3	Reserved				Reserved			
	Bit7	Bit6	Bit5	Bit4	Bit3	Bit2	Bit1	Bit0
byte2	Reserved				TEMPERATURE_1 Factor			
	Bit7	Bit6	Bit5	Bit4	Bit3	Bit2	Bit1	Bit0
byte1	FAN_SPEED Factor				VIN Factor			
	Bit7	Bit6	Bit5	Bit4	Bit3	Bit2	Bit1	Bit0
byte0	IOUT Factor				VOUT Factor			

byte0:

Bit 0:3 VOUT Factor : The factor of output voltage

0x0=Output voltage relevant commands not supported

0x4=0.001

0x5=0.01

0x6=0.1

0x7=1.0

0x8=10

0x9=100

0x0A~0xFF= Reserved

Bit 4:7 IOUT Factor : The Factor of DC current

0x0=Output current relevant commands not supported

0x4=0.001

0x5=0.01

0x6=0.1

0x7=1.0

0x8=10

0x9=100

0x0A~0xFF= Reserved

byte1:

Bit 0:3 VIN Factor : The Factor of AC input voltage

0x0=AC input relevant commands not supported

0x4=0.001

0x5=0.01

0x6=0.1

0x7=1.0

0x8=10

0x9=100

0x0A~0xFF= Reserved

Bit 4:7 FAN_SPEED Factor : The Factor of fan speed

0x0=Fan speed relevant commands not supported

0x4=0.001

0x5=0.01

0x6=0.1

0x7=1.0

0x8=10

0x9=100

0x0A~0xFF= Reserved

byte2:

Bit 0:3 TEMPERATURE_1 Factor : The Factor of internal ambient temperature

0x0=internal ambient temperature relevant commands not supported

0x4=0.001

0x5=0.01

0x6=0.1

0x7=1.0

0x8=10

0x9=100

0x0A~0xFF= Reserved

◎SYSTEM_STATUS(0x00C3) :

	Bit7	Bit6	Bit5	Bit4	Bit3	Bit2	Bit1	Bit0
High byte	-	-	-	-	OLP_MODE	-	-	RC
Low byte	-	EEPER	INITIA-LSTATE	ADL_ON	ORING_OFF	PFC_OK	DC_OK	M/S

Low byte:

Bit 0: M/S : parallel mode status

0 = Current device is Slave

1 = Current device is Master

Bit 1 DC_OK : Secondary DD output voltage status

0 = Secondary DD output voltage status TOO LOW

1 = Secondary DD output voltage status NORMAL

Bit 2: PFC_OK : Primary PFC status

0 = Primary PFC OFF or abnormal

1 = Primary PFC ON normally

Bit 3: ORING_OFF :

0 = Disable ORING MOS after Secondary DD turn ON

1 = Enable ORING MOS after Secondary DD turn ON

Bit 4 ADL_ON : Active dummy load control status

0 = Active dummy load off/function not supported

1 = Active dummy load on

Bit 5 INITIAL_STATE : Device initialized status

0 = NOT in initialization status

1 = In initialization status

Bit 6 EEPER : EEPROM data access error

0 = EEPROM data access normal

1 = EEPROM data access error

Note. When EEPROM data is corrupted, the PSU will shut down and enter protection mode. The PSU will restart only after the issue is resolved and the unit is power cycled.

High Byte:

Bit 0: RC: Remote ON/OFF state

0 = Currently in Remote OFF state

1 = Currently in Remote ON state

Bit 2:3 OLP_MODE: Overload Protection (OLP) mode status

0b00 = Constant current limiting with a 5-second delayed shutdown during overload(2 sec for 12V/15V model)

0b01 = Continuous constant current limiting during overload

0b10 = Reserved

0b11 = Reserved

Note: Unsupported settings displays with "0"

◎SYSTEM_CONFIG (0x00C4) :

	Bit7	Bit6	Bit5	Bit4	Bit3	Bit2	Bit1	Bit0
High byte						EEP_OFF	EEP_CONFIG	
Low byte	-	-	-	-	-	OPERATION_INI		MOD_CTRL

Low byte:

Bit 0

MOD_CTRL : Modbus communication control status

0 = The output voltage/current defined by control over SVR/PV/PC (factory default)

1 = The output voltage, current, ON/OFF control defined by control over Modus (VOUT_SET, IOUT_SET, OPERATION)

Bit 1:2

OPERATION_INIT : Pre-set value of power on operation command

0b00 = Power OFF, pre-set 0x00(OFF)

0b01 = Power ON, pre-set 0x01(ON) (factory default)

0b10 = Pre-set is previous set value

0b11 = not used, reserved

High Byte:

Bit 0:1 EEP_CONFIG: EEPROM Configuration

0b00 = Immediate. Changes to parameters are written to EEPROM immediately (factory default)

0b01 = 1 minute delay. Write changes to EEPROM if all parameters remain unchanged for 1 minute

0b10 = 10 minute delay. Write changes to EEPROM if all parameters remain unchanged for 10 minutes

0b11 = Reserved

Bit 2 EEP_OFF: EEPROM storage function ON/OFF

0 = Enable. Parameters to be saved into EEPROM (factory default)

1 = Disable. Parameters NOT to be saved into EEPROM

Note: Unsupported settings displays with "0"

©PROTECT_CONFIG(0x00C5)

	Bit7	Bit6	Bit5	Bit4	Bit3	Bit2	Bit1	Bit0
High byte	-	-	-	-	-	-	-	-
Low byte	-	-	-	-	-	-	-	OLP_TYPE

Low byte:

Bit 0 OLP_TYPE: OLP Configuration

0 = Constant current limiting with a 5-second delayed shutdown during overload(2 sec for 12V/15V model)

1 = Continuous constant current limiting during overload

Note: Unsupported settings displays with "0"

©CLEAR_LOG (0x0910): The command clears the data stored in EVENT_0 to EVENT_4 (0x0921-0x0925). Event log data is stored in the EEPROM and remains intact after power off. To clear the event logs, write 0x00AA to CLEAR_LOG (0x0910). For example, to clear the event logs for the PSU at Address 01, the command format is as follows:

Slave Address	Function Code	Data Address of the register	Data	CRC
0x81	0x6	0x0910	0x00AA	0x142C

0x81: Slave ID 01

0x06: Function code 6 (Preset Single Register)

0x0910: The Data Address of the register CLEAR_LOG

0x00AA: The value to write

0x142C: CRC16 Error Check. Please be aware that CRC sending the Lo byte first.

©EVENT_0 to EVENT_4 (0x0921-0x0925): Sequentially store the five most recent event logs. Refer to the table below for the mapping between event codes and their corresponding conditions.

Commands	Event (Decimal)	Event (Hexadecimal)	Event Description
EVENT_0 (0x0921)	0001	0x0001	Overload Protection (OLP)
	0002	0x0002	Over Voltage Protection (OVP)
	0006	0x0006	Short Circuit Protection (SCP)
EVENT_1 (0x0922)	4001	0x0FA1	Over Temperature Protection (OTP)
EVENT_2 (0x0923)	4002	0x0FA2	Under Temperature Protection (UTP)
EVENT_3 (0x0924)		4004	0x0FA4
EVENT_4 (0x0925)	4005	0x0FA5	Hardware Error
	4006	0x0FA6	Internal communication error
	4007	0x0FA7	EEPROM Error

The latest event is always stored in EVENT_0 (0x0921), and the remaining events are shifted accordingly from EVENT_1 (0x0922) to EVENT_4 (0x0925). When the number of events exceeds five, the oldest event is discarded from the event log. Refer to the table below for the sequence of events and data shifting logic.

Timing/Event Command	T1 (Earliest)	T2	T3	T4	T5	T6 (Latest)
	Fan Fail	OTP	SCP	OLP	OVP	OLP
EVENT_0 (0x0921)	4004	4001	0006	0001	0002	0001
EVENT_1 (0x0922)	0	4004	4001	0006	0001	0002
EVENT_2 (0x0923)	0	0	4004	4001	0006	0001
EVENT_3 (0x0924)	0	0	0	4004	4001	0006
EVENT_4 (0x0925)	0	0	0	0	4004	4001
Remark	4004 stored in EVENT_0	4001 stored in EVENT_0; existing logs shift	0006 stored in EVENT_0; existing logs shift	0001 stored in EVENT_0; existing logs shift	0002 stored in EVENT_0; existing logs shift	0001 stored in EVENT_0; existing logs shift; 4004 pushed out

6.2.6 Communication Examples

The following provides examples of request and response for each function code of the Modbus RTU.

6.2.6.1 Read Holding Registers (FC=03)

The request message specifies the starting register and quantity of registers to be read.

For example: the master requests the content of analog output holding registers 0x008C-0x008E (MFR_REVISION_B0B5) from slave 1.

Request:

0x81	0x03	0x008C	0x0003	0xDBE0
------	------	--------	--------	--------

0x81: Slave ID 01

0x03: Function code 3 (Read Analog Output Holding R Registers)

0x008C: The Data Address of the first register requested.

0x0003: The total number of registers requested (Read 3 registers from 0x008C to 0x008E)

0xDBE0: CRC16 Error Check. Please be aware that CRC sending the Lo byte first.

Response:

0x81 0x03 0x06 0x0AFFFFFFF 0x5599

0x81: Slave ID 01
 0x03: Function code 3 (Read Analog Output Holding R Registers)
 0x06: The number of data bytes to follow (6 bytes)
 0x0A FF FF FF FF FF: means that the firmware version of the MCU number1 is R01.0.
 0x5599: CRC16 Error Check. Please be aware that CRC sending the Lo byte first.

6.2.6.2 Read Input Register (FC=04)

The request message specifies the starting register and quantity of registers to be read. For example: The master requests the content of analog input register 0x0060 (READ_VOOUT) from slave 1

Request:

0x81 0x04 0x0060 0x0001 0x2E14

0x81: Slave ID 01
 0x04: Function code 4 (Read Analog Input Registers)
 0x0060: The Data Address of the first register requested
 0x0001: The value to write
 0x2E14: CRC16 Error Check. Please be aware that CRC sending the Lo byte first

Response:

0x81 0x04 0x02 0x157C 0xB79F

0x81: Slave ID 01
 0x04: Function code 4 (Read Analog Input Registers)
 0x02: The number of data bytes to follow (2 bytes)
 0x157C: The contents of register: 0x0060(READ_VOOUT). $157C_{16} = 5500_{10} = 55.00V$
 0xB79F: CRC16 Error Check. Please be aware that CRC sending the Lo byte

6.2.6.3 Write Single Register (FC=06)

The request message specifies the register reference to be written. For example: the master writes PSU ON to analog output holding register of 0x0000 (OPERATION) for slave 1

Request:

0x81 0x06 0x0000 0x0001 0x57CA

0x81: Slave ID 01
 0x06: Function code 6 (Preset Single Register)
 0x0000: The Data Address of the register
 0x0001: The value to write
 0x57CA: CRC16 Error Check. Please be aware that CRC sending the Lo byte first

Response:

The normal response is an echo of the query, returned after the register contents have been written.

6.2.6.4 Practical Operation

The following steps will describe how to set the NSP-2400-60 to 56V.

1. Set the ID of the power supply to "1". Connect the A0(PIN 7), A1(PIN 8), A2(PIN 9), and A3(PIN 10) to GND(PIN 11 or PIN 12), all on the CN1.

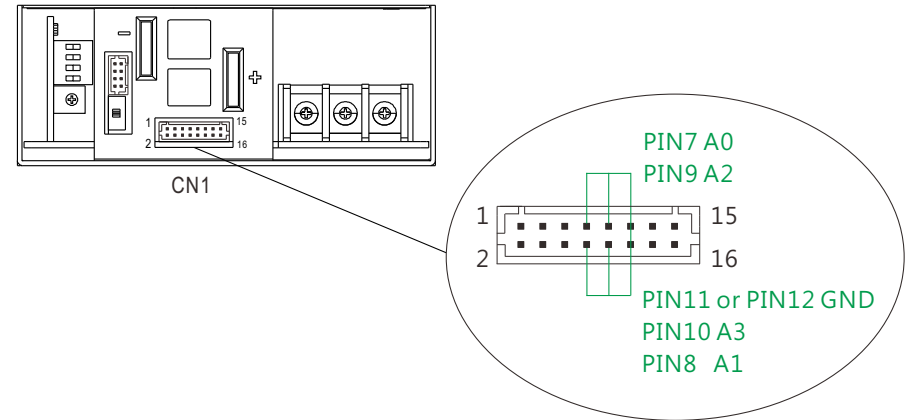

2. Connect the DATA+ /DATA- pins of the master to the corresponding D+ (PIN 7) and D- (PIN 8) pins of the CN2 connector on the PSU. It is recommended to establish a common ground for the communication system to increase its communication reliability by using GND-AUX (PIN 4 or PIN 6) of CN2.

Control	Setting
Baud Rate	115200
Data Bits	8
Stop Bit	1
Parity	None
Flow Control	None

- ⊙ Adding a 120Ω termination resistor to both the controller and supply's end can increase communication stability.
- ⊙ For units configured as a bus terminal, the termination resistor should be enabled by setting SW2 to ON.

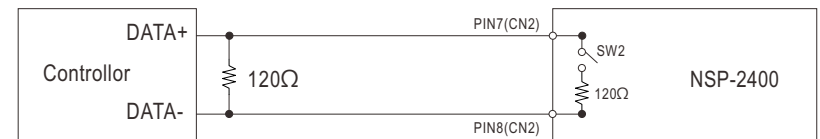

3. Configure communication settings after power on. Enable communication mode and set power ON when AC connected.

Slave Address	Function Code	Data Address of the register	Data	CRC
0x81	0x06	0x00C2	0x0003	0x77F7

0x81: Slave ID 01

0x06: Function code 6 (Write Single Register)

0x00C2: SYSTEM_CONFIG register

0x0003: The value to write. Please refer to definition of SYSTEM_CONFIG for detailed information

0x77F7: CRC16 Error Check

4. Set Output voltage to 56V

Slave Address	Function Code	Data Address of the register	Data	CRC
0x81	0x06	0x0020	0x15E0	0x98D8

0x81: Slave ID 01

0x06: Function code 6 (Write Single Register)

0x0020: VOUT_SET register

0x15E0: 56V → 5600 → 0x15E0

0x98D8: CRC16 Error Check

Note: Conversion factor for VOUT_SET is 0.01, so $\frac{56V}{F=0.01} = 5600$

5. It is recommended to review all of the settings and parameters using the appropriate commands. In the event that they do not meet your requirements, you may rewrite them as needed. EX: Read VOUT_SET to check whether output voltage was set to a proper level.

Read VOUT_SET

Slave Address	Function Code	Data Address of the first register requested	The total number of registers requested	CRC
0x81	0x03	0x0020	0x0001	0x9A00

The unit returns data below

Slave Address	Function Code	The number of data bytes to follow	Data	CRC
0x81	0x03	0x01	0x15E0	0x4682

Data: 0x15E0 → 5600 = 56V

6. Finally, check whether R.C (PIN 1) and +5-AUX (PIN 2) pins of the CN2 connector are short-circuited if there is no output voltage.

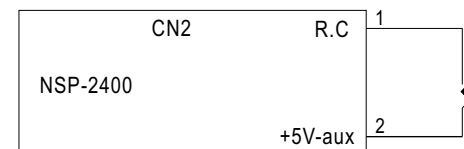

6.3 Value range and tolerance

(1) Display Parameters

CAN bus/Modbus Command	Model	Display value range	Tolerance
0x0050	READ_VIN	ALL	80~310V ±4.60V
0x0060	READ_VOUT	12V	0~16V ±0.12V
		15V	0~24V ±0.15V
		24V	0~32V ±0.24V
		27V	0~35V ±0.27V
		36V	0~50V ±0.36V
		48V	0~60V ±0.48V
		60V	0~80V ±0.60V
0x0061	READ_IOUT (Note. ii)	12V	0~375A ±1.9A
		15V	0~300A ±1.5A
		24V	0~205A ±1.0A
		27V	0~185A ±0.9A
		36V	0~135A ±0.7A
		48V	0~105A ±0.5A
		60V	0~85A ±0.4A
0x0062	READ_TEMPERATURE_1	ALL	-50~110°C ±5°C

(2)Control Parameters

CAN bus/Modbus Command		Model	Programmable range	Tolerance	Default
0x0000	OPERATION	ALL	00h(OFF)/01h(ON)	N/A	ON
0x0020	VOUT_SET	12V	0~14.4V	±0.12V	12V
		15V	0~19V	±0.15V	15V
		24V	0~28.8V	±0.24V	24V
		27V	0~32.4V	±0.27V	27V
		36V	0~43.2V	±0.36V	36V
		48V	0~55V	±0.48V	48V
		60V	0~72V	±0.60V	60V
0x0030	IOUT_SET	12V	0~196.2A	±1.9A	196.2A
		15V	0~157A	±1.5A	157A
		24V	0~107A	±1.0A	107A
		27V	0~95A	±0.9A	95A
		36V	0~71.3A	±0.7A	71.3A
		48V	0~53.5A	±0.5A	53.5A
		60V	0~42.8A	±0.4A	42.8A
0x00C2/ 0x00C4	SYSTEM_CONFIG	ALL	N/A	N/A	02h
0x00C3/ 0x00C5	PROTECT_CONFIG	ALL	N/A	N/A	00h

Note:

i.READ_IOUT will display ZERO Amp when output current is less than values in the table below.

Model	Minimum readable current
12V	1.9A±1.9A
15V	1.5A±1.5A
24V	1.0A±1.0A
27V	0.9A±0.9A
36V	0.7A±0.7A
48V	0.5A±0.5A
60V	0.4A±0.4A

ii.As depicted by the PV/PC control curves, the control command is recognized as 0% when VOUT_SET or IOUT_SET is set below the threshold values listed in the table below.

Model	VOUT_SET	IOUT_SET
12V	0.12V	1.9A
15V	0.15V	1.5A
24V	0.24V	1.0A
27V	0.27V	0.9A
36V	0.36V	0.7A
48V	0.48V	0.5A
60V	0.60V	0.4A

iii.Owing to the limited write cycles of the EEPROM, it is advisable to consider using the SYSTEM_CONFIG (CAN bus: 0x00C2; Modbus: 0x00C4) command to select an appropriate EEPROM writing logic, especially if communication settings are frequently altered.

7. Protections and Trouble Shooting

7.1 Protections

7.1.1 Over Load Protection (OLP)

When the load current exceeds the overload condition specified in the datasheet, the protection circuit will activate and shut down the output. To restore normal operation, power cycle the PSU once the overload condition is cleared.

7.1.2 Over Voltage Protection (OVP)

When the output voltage exceeds the overvoltage threshold, the protection circuit will activate and shut down the output. To restore normal operation, power cycle the PSU once the over voltage condition is cleared.

7.1.3 Over Temperature Protection (OTP)

When the internal temperature exceeds the specified threshold (See Section 2.4), the output will shut down (while the fan continues to operate for cooling). To recover, turn off the AC power, eliminate any factors that may cause overheating, and allow the PSU to cool down to normal temperature (this may take several tens of minutes) before turning it back on again.

7.1.4 Fan Fail Protection

If the fan speed is detected as zero after power-on, the protection circuit will activate and shut down the output. Check for any obstructions that may interfere with fan rotation. After resolving the fan malfunction, power cycle the PSU to restore normal operation.

7.1.5 Short Circuit Protection (SCP)

When the output is short-circuited, the protection circuit will activate and shut down the output. After clearing the short circuit condition, power cycle the PSU to restore normal operation.

7.1.6 AC Input Under-Voltage Protection (AC_UVP)



When the input voltage falls below the range specified in the datasheet, the protection circuit will activate and shut down the output. After the condition is cleared, power cycle the PSU to restore normal operation.





7.1.7 Under Temperature Protection (UTP)

When the internal temperature drops below the specified threshold (See Section 2.4), the output will shut down. Disconnect the AC power and increase the ambient temperature. To prevent condensation from rapid temperature rise, increase the ambient temperature gradually. Ensure the PSU remains within the operating temperature range for a sufficient period (e.g., several tens of minutes) before a power cycle.

7.2 Trouble Shooting

The fault conditions listed in the table below can be identified by the LED indicator status. If the issue cannot be resolved, please contact your local authorized Mean Well distributor or the factory for assistance.

Category / Light Signal	Reason	Troubleshooting Suggestions
Remote OFF ● Red	CN2 PIN 1 (R.C) and PIN 2 (+5V-AUX) are not connected together.	Ensure that CN2 PIN 1 (R.C) is connected to PIN 2 (+5V-AUX).
High Ambient Temperature Alarm ☀ Orange: 1 Blink/Pause 	Internal temperature at critical level. Unit still operational.	Ensure adequate ventilation clearance. Verify that input voltage and ambient temperature comply with the derating curve (Section 2.4) to prevent OTP.
Over Load Protection/ Short Circuit Protection ☀ Red: 1 Blink/Pause 	1.The actual output current is higher than the rated current in the datasheet. 2.Short circuit protection active.	1.Remove the load and restart the device. If the unit recovers, gradually reapply the load while monitoring the output. 2.Check if there is short circuit at the output.
Over Voltage Protection ☀ Red: 2 Blink/Pause 	The output voltage exceeded the overvoltage threshold and shut down the output.	Ensure that no external DC power source is connected and that the voltage is within the OVP range specified in the datasheet.

Category / Light Signal	Reason	Troubleshooting Suggestions
Over Temperature Protection ☀ Red: 3 Blink/Pause 	Overheating of internal components.	Ensure adequate ventilation clearance. Verify that input voltage and ambient temperature comply with the derating curve (Section 2.4). Allow the PSU to cool to normal temperature range before a power cycle for testing.
Fan Fail Protection ☀ Red: 4 Blink/Pause 	No fan rotation was detected after power-on.	Check for foreign objects or other obstructions preventing fan rotation.
AC Under Voltage Protection ☀ Red: 5 Blink/Pause 	The AC input voltage is lower than the range specified in the datasheet.	Ensure that the input voltage is within the range specified in the datasheet.
Other ☀ Red: 6 Blink/Pause 	1.Under Temperature Protection 2.EEPROM error.	1.Increase the ambient temperature gradually. 2.Use communication to verify if an EEPROM error exists. If the issue persists after a power cycle or factory resetting (refer to Section 5.14), please contact your MEAN WELL distributor.

8.Warranty

This product provides 5 years warranty under normal usage. Do not replace parts or any form of modification to the product in order to keep the warranty effectively.

※ MEAN WELL possesses the right to adjust the content of this manual.

Please refer to the latest version of manual on our website.

<https://www.meanwell.com>



9.Environmental Declaration Information

https://www.meanwell.com//Upload/PDF/RoHS_PFOS.pdf

https://www.meanwell.com//Upload/PDF/REACH_SVHC.pdf

https://www.meanwell.com//Upload/PDF/Declaration_RoHS-E.pdf

明緯企業股份有限公司

MEAN WELL ENTERPRISES CO., LTD.

248 新北市五股區五權三路28號

No.28, Wuquan 3rd Rd., Wugu Dist., New Taipei City 248, Taiwan

Tel:886-2-2299-6100 Fax:886-2-2299-6200

<http://www.meanwell.com> E-mail:info@meanwell.com